

T-piece Resuscitator | Technical Manual



TABLE OF CONTENTS

1. Specifications.....	2
1.1 About this manual	3
1.2 Warnings	2
1.3 Performance Specifications.....	2
1.4 Technical Specifications.....	2
1.5 Symbol Definitions.....	3
1.6 Label Identification	3
2. Cleaning	4
3. Service Information.....	4
3.1 Functional Schematic.....	4
3.2 Maintenance Schedule	4
3.3 Workflow Diagram	4
3.4 Physical Checks.....	4
3.5 Installation Checks and Preventative Maintenance	4
3.5.1 Installation Checks.....	4
3.5.2 Preventative Maintenance	4
3.6 Testing of the F&P Neopuff™ Performance (Manometer and Valve System).....	5
3.6.1 Testing of the Manometer.....	5
3.6.2 Testing of the Valve System.....	5
3.7 Service	5
3.7.1 Setting Max Pressure Relief to 40 cmH ₂ O.....	6
3.7.2 Resetting the Manometer to Zero	6
3.8 Replacement/Repair.....	6
3.8.1 Manometer Replacement.....	6
3.8.2 Valve System Replacement	6
3.8.3 Trim Replacement	6
3.9 Set-up and Maintenance Checklist	7
4. Assembly Diagrams	8
4.1 F&P Neopuff Infant Resuscitator (Post June 2010).....	8
4.1.1 Assembly Diagram.....	8
4.1.2 Parts List.....	8
4.1.3 Spares Kit.....	9
5. Mounting Options.....	10
5.1 900RD301 Side-Mounting Block.....	10
5.2 900MR088 Rail Mount Bracket.....	10
5.3 RD050-01 Pole and Rail Central Mount.....	11

1. SPECIFICATIONS

1.1 About this manual

This manual is intended for use by service and maintenance personnel who are qualified to perform maintenance and servicing on medical devices like the F&P Neopuff T-Piece Resuscitator and its accessories. It details the product specifications, maintenance procedure, and servicing instructions.

This manual is intended to be used in conjunction with the F&P Neopuff T-Piece Resuscitator User Instructions.

Intended Purpose: The F&P Neopuff T-piece Resuscitator (RD900AEU/ADU/ASU) is a reusable, manually operated, gas-powered resuscitator which provides ventilatory support to neonates and infants with respiratory insufficiency. This device is designed for use in the hospital environment and must be prescribed by a physician. It is intended to be used by medical professionals including physicians, nurses, midwives and respiratory therapists. The intended population for use is neonates and infants.

1.2 Warnings

- Dropping the F&P Neopuff T-piece Resuscitator or other similar forms of impact may cause damage resulting in incorrect operation of the unit.
- Do not use oil, grease or other substances that are incompatible with oxygen on any part of the F&P Neopuff T-piece Resuscitator system.
- Ensure all oxygen and air supplies are turned off and disconnected from the Neopuff before performing cleaning procedures. Explosion and fire hazards can exist when performing cleaning procedures in an oxygen-enriched environment.
- As this medical device uses an alternative small-bore connector design different from those specified in the ISO 80369 series, there is a possibility that a misconnection can occur between this medical device and a medical device using a different alternative small-bore connector, which can result in a hazardous situation causing harm to the patient. Special measures need be taken by the user to mitigate these reasonable foreseeable risks.

1.3 Performance Specifications

Peak Inspiratory Pressure (PIP) Range	
@ 5 L/min	approx. 2 to 70 cmH ₂ O [mbar]
@ 8 L/min	approx. 3 to 72 cmH ₂ O [mbar]
@ 10 L/min	approx. 4 to 73 cmH ₂ O [mbar]
@ 15 L/min	approx. 8 to 75 cmH ₂ O [mbar]
Positive End Expiratory Pressure (PEEP) Range	
@ 5 L/min	approx. 1 to 6 cmH ₂ O [mbar]
@ 8 L/min	approx. 1 to 10 cmH ₂ O [mbar]
@ 10 L/min	approx. 2 to 15 cmH ₂ O [mbar]
@ 15 L/min	approx. 4 to 17 cmH ₂ O [mbar]
Input Gas Flow Range	
Minimum	5 L/min
Maximum	15 L/min
Operating Time (400 L Cylinder)	
5 L/min	80 minutes
10 L/min	40 minutes
15 L/min	26 minutes
NOTE: All performance figures listed above are representative only. PEEP values stated are based on typical clinical PIP settings. Higher PEEP values can be achieved if higher PIP values are set.	

1.4 Technical Specifications

Height	250 mm (9.8")
Width	200 mm (7.9")
Depth	104 mm (4.1")
Weight	1.9 kg (4.2 lb)
Manometer Range	-10 to 80 cmH ₂ O [mbar]
Manometer Accuracy	+/-2.0% of Full Scale Deflection
Maximum Pressure Setting	65 to 80 cmH ₂ O [mbar] (dependent on flow rate)
Storage Temperature Range	-10 to 50 °C (+14 to +122 °F), up to 95% humidity
Operating Temperature Ranges	
Humidified Circuit	+18°C to 26 °C (+64 to +78 °F), 30 - 75% humidity
Non-Humidified Circuit	-18 to +50 °C (-0.4 to +122 °F), up to 95% humidity
Recommended Patient Body Weight	0 to 10 kg (22 lb)
Delivered Oxygen Concentration	Up to 100% depending on gas supply
Service life	The Neopuff T-piece Resuscitator has an expected service life of 10 years Test Lung (RD020-01): 12 Months Gas Supply Line (900RD008 & 900RD009): 12 Months Gas Inlet Adapter (900RD101): 12 Months

1. SPECIFICATIONS continued

1.5 Symbol Definitions

SYMBOL	DEFINITION
	Attention: Consult the Operating Instructions www.fphcare.com/neopuff-ifu
	Sets the Max Pressure Relief that may be delivered to the patient (factory set at 40 cmH ₂ O)
	Controls the Peak Inspiratory Pressure delivered to the patient
	Gas inlet connection from gas supply (5 to 15 litres per minute)
	Gas outlet connection to patient
	Date of manufacture & country code
	Manufacturer
Rx only	Prescription only
	Batch code
	Catalogue number
	Authorized representative in the European Community
	Medical device
	This product is not made with natural rubber latex.
	Storage temperature range
	Serial number
	Importer
	Recyclable packaging
	Distributor
	Not made with phthalates (DEHP, DBP, BBP).
	CE Mark
	UKCA mark

1.6 Label Identification

The label pictured is typical of the information contained on a F&P Neopuff T-piece Resuscitator.

REF RD900AEU

[en] Neopuff™ Infant T-Piece Resuscitator

2023-02-01

LOT 1111111111

SN 111111111111

EC REP Fisher & Paykel Healthcare SAS
10 Av. du Québec, Bât. F5, BP 512,
91946 Courtaboeuf Cedex, France

P/N: 183043345_B

QTY: 1 EA
UoM: EA

CE 0123

Rx only **MD**

(01) 09420012410931
(10) 1111111111
(11) 230201
(21) 111111111111

Fisher & Paykel
HEALTHCARE

RD900	XXX	Operating Instruction Language	Fascia Type
RD900 T-Piece Resuscitator	AEU	English, Arabic, Indonesian, Korean, Russian, Thai, Traditional Chinese, Urdu, Vietnamese, French	English
	ADU	English, German, Dutch, Bulgarian, Croatian, Czech, Danish, Estonian, Finnish, Greek, Hungarian, Italian, Latvian, Lithuanian, French, Polish, Portuguese, Romanian, Slovakian, Slovenian, Swedish, Norwegian, Turkish, Spanish, Portuguese - Brazilian	Symbol
	ASU		
	AZU	Simplified Chinese	

2. CLEANING

Refer to the User Instructions which accompany each device for cleaning guidelines.

3. SERVICE INFORMATION

3.1 Functional Schematic

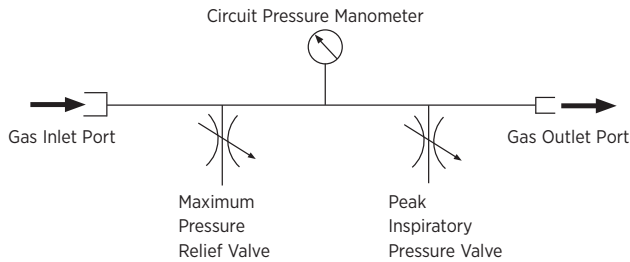

3.2 Maintenance Schedule

Activity	Frequency		
	Prior to first use	After Servicing	Annually
Installation Checks	✓		
Preventative Maintenance	✓	✓	✓
Performance Testing		✓	

3.3 Workflow Diagram

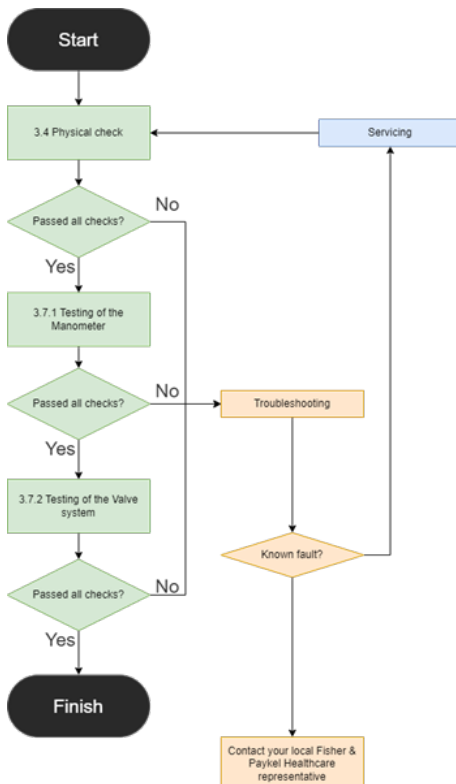

3.4 Physical Checks

Carry out a physical check on the F&P Neopuff T-Piece Resuscitator by following the instructions specified in the table below. If any components are damaged, follow the instructions specified in the “corrective action” column to repair or replace the component.

Inspection Instructions	Corrective Action	Corrective Action Reference
Check the top of the unit for damage/cracks	If damage present, confirm functionality of valve and manometer. Replace as necessary.	3.8.3 Trim Replacement
Check the bottom of the unit for damage/cracks	If damage present, confirm functionality of valve and manometer. Replace as necessary.	3.8.3 Trim Replacement
Check the front panel of the unit, manometer, and valve assembly for damage/cracks	If damage present, confirm functionality of valve and manometer. Replace as necessary.	3.8.1 Manometer Replacement, 3.8.2 Valve System Replacement

3.5 Installation Checks and Preventative Maintenance

WARNING Dropping the F&P Neopuff T-piece Resuscitator or other similar forms of impact may cause damage resulting in incorrect operation of the unit. If you suspect damage to have occurred, please perform checks as outlined in section 3.6 before connection to a patient.

3.5.1 Installation Checks

Prior to first use:
 – Remove manometer cover
 – Complete Performance Testing (section 3.6)

3.5.2 Preventative Maintenance

- The integrity of the system and manometer should be checked prior to first use, annually and after servicing, using the “Testing of the F&P Neopuff Performance” procedure (section 3.6).
- The use of a mounting bracket to help prevent the F&P Neopuff being damaged or dropped is recommended. Mounting solutions available can be found in section 5 of this manual.
- All maintenance and service procedures must be performed by qualified personnel using only Fisher & Paykel Healthcare parts.
- Always ensure gas passages are free from contaminants, especially hydrocarbons, oils and grease, prior to reassembly.
- Please contact an authorized Fisher & Paykel Healthcare representative for further assistance with any servicing or maintenance requirements.
- The Test Lung is a consumable item; it should be monitored for signs of wear and material degradation and replaced as required.

3.6 Testing of the F&P Neopuff Performance (Manometer and Valve System)

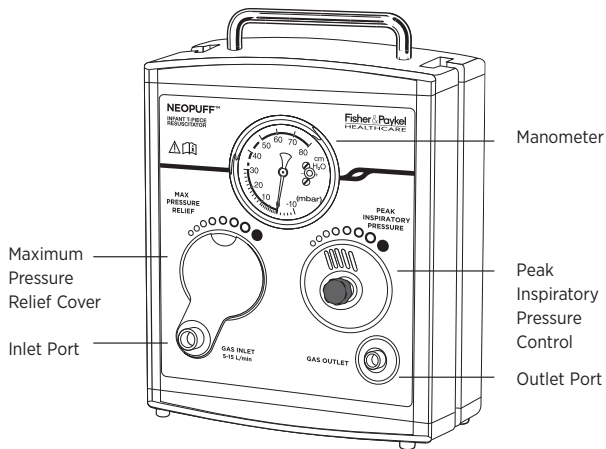

The integrity of the F&P Neopuff manometer and valve system can be tested using the following guidelines. The inlet port must be connected to a gas supply capable of generating constant flow at 5, 10 and 15 L/min, and a certified gauge and bleed valve should be available to check the manometer accuracy. The F&P Neopuff/Perivent resuscitation circuit and T-Piece can be used in place of a bleed valve as shown below.

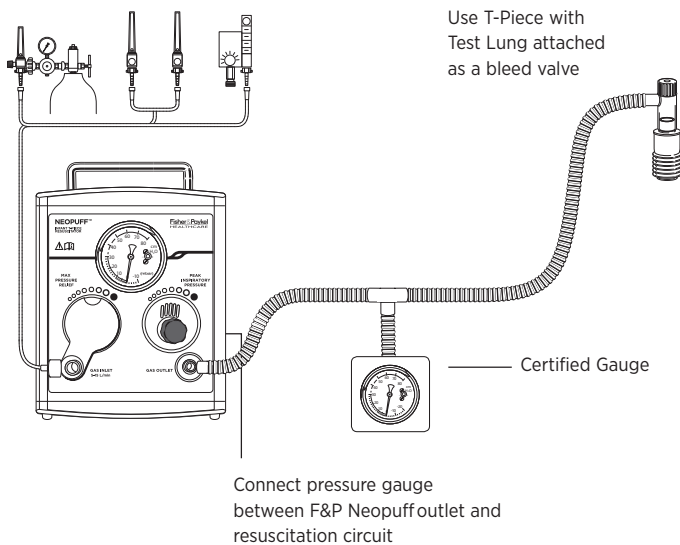

3.6.1 Testing of the Manometer

1. Lift the cover off the Max Pressure Relief Valve slightly and turn out of the way.
2. Disconnect all devices from the F&P Neopuff outlet port. Check that the manometer needle is within +/-2 cmH₂O of zero on the manometer gauge. If the manometer does not read zero, the resetting of the manometer to zero procedure (section 3.7.2) should be followed.
3. Connect the outlet of the F&P Neopuff T-piece Resuscitator to a bleed valve and a certified gauge (e.g. Mensor Digital Pressure Gauge Series 2400). Set the gas supply to 10 L/min. Completely close the maximum pressure limit valve by turning the left-hand knob completely clockwise. With the bleed valve closed, adjust the Peak Inspiratory Pressure knob to set the pressure so that the certified gauge reads 10, 20 and 40 cmH₂O. Check that the manometer reads within +/-2 cmH₂O of these values at each set point.
4. With the pressure set to 40 cmH₂O, open and close the bleed valve three times and check the manometer needle rises and falls smoothly. **If the F&P Neopuff T-piece Resuscitator fails any of these tests, the manometer should be regarded as inaccurate and replaced with a new manometer (Part No. 043040841).**

Follow the manometer replacement guidelines in section 3.7.1 of this manual, or contact your Fisher & Paykel Healthcare service representative for further guidance.

3.6.2 Testing of the Valve System

1. Set the gas supply to 5 L/min. Completely close the Peak Inspiratory Pressure control and the Max Pressure control by turning both knobs completely clockwise. Close the bleed valve and check that the gauge reads at least 60 cmH₂O.
2. Set the gas supply to 15 L/min. Close the bleed valve and check that the gauge reads no higher than 80 cmH₂O.
3. Set the gas supply to 10 L/min. Close the bleed valve and turn the Max Pressure Relief valve until the manometer reads 40 cmH₂O. Check that the manometer needle rises and falls smoothly. Gently rotate the Max Pressure Relief cover over the Max Pressure Relief knob.
4. Reset the peak inspiratory pressure to 20 cmH₂O and turn off the gas flow. Testing is now complete.

If the F&P Neopuff T-piece Resuscitator fails any of these tests, the valve assembly should be regarded as faulty and replaced with a new valve assembly (see the parts list (section 4.1.2) for part numbers). Follow the valve replacement guidelines in section 3.8.2 of this manual, or call your Fisher & Paykel Healthcare service representative for further information.

3. SERVICE INFORMATION continued

3.7 Service

3.7.1 Setting Max Pressure Relief to 40 cmH₂O

This is required if the Max Pressure Relief has been changed. The factory setting for the Max Pressure Relief is 40 cmH₂O.

Alternative settings for the Max Pressure Relief should be made in accordance with hospital protocol.

1. Adjust gas flow to 10 L/min.
2. Close the Peak Inspiratory Pressure valve by turning the knob fully clockwise.
3. Adjust the Max Pressure Relief knob clockwise or counterclockwise until the manometer reads 40 cmH₂O.
4. Turn the Peak Inspiratory Pressure knob counterclockwise so the manometer reads 20 cmH₂O and shut off the gas flow.

3.7.2 Resetting the Manometer to Zero

To set the manometer to zero:

1. Disconnect the F&P Neopuff T-piece Resuscitator from any other equipment.
2. Remove the opaque plastic plug in the lens of the manometer.
3. Using a suitable slot screwdriver, carefully adjust the screw in the manometer face clockwise or counterclockwise to reset the manometer to zero. Care must be taken when doing this, as over-rotation of the screw can damage the manometer internals.
4. Replace the plastic plug in the lens of manometer.
5. Verify that the manometer needle is now within +/-2.0 cmH₂O of zero. If not, repeat the above procedure.

3.8 Replacement/Repair

3.8.1 Manometer Replacement

The manometer is not a serviceable item and must be replaced by Manometer Kit RD064.

1. Remove the back cover, fixed by four screws.
2. Disconnect the tube from the manometer.
3. Remove the manometer by unscrewing the two retaining nuts.
4. Fit the new manometer into the front panel, tighten the retaining nuts and reconnect the manometer tube.
5. Refit the front panel to the back cover with the four screws.
6. Carry out the manometer performance test as per section 3.6.1. It is recommended to record the lot number from the box label of the replacement manometer on the maintenance checklist.

3.8.2 Valve System Replacement

NOTE: The valves are an integral part of the valve, panel and manifold assembly and are not able to be serviced. Please specify the model number from the parts list (section 4.1.3) when ordering a replacement valve assembly.

1. Remove the back cover, fixed by four screws.
2. Disconnect the tube from manometer.

3. Remove the manometer by unscrewing the two retaining nuts.
4. Fit the existing manometer into the new valve assembly panel, tighten the retaining nuts and reconnect the manometer tube.
5. Refit the front panel to the back cover with the four screws from step 1.
6. Carry out the valve system performance test as per section 3.6.2. It is recommended to record the lot number of the new valve assembly onto the Set-up and Maintenance Checklist.

3.8.3 Trim Replacement

All replaceable trim parts are push fit components. Refer to Section

4. Assembly Diagrams for guidance on locating the parts.

3. SERVICE INFORMATION continued

3.9 Set-up and Maintenance Checklist

The following table is provided to record the results of the performance tests described in section 3.6. Any components replaced should be recorded also, as appropriate. The table may be photocopied or otherwise reproduced as required.

Upon receipt of the product and prior to use on a patient, please complete the tests and fill in the table below.

Customer Details	Name:			
	Address:			
	Country:			
	Phone Number:			
	Email:			
F&P Neopuff Performance Testing Record	Test Date:			
	Serial Number:			
	For 900IW130 only: Infant Warmer Serial Number:			
	Tested By:			
	Next Test Due Date:			
Check	Ref	✓ or X	Comments	
Manometer Checks:				
Replacement Manometer Serial Number:				
Accuracy @ 0 cm (+/-2 cmH ₂ O)	3.6.1-2			
Accuracy @ 10 cm (+/-2 cmH ₂ O)	3.6.1-3			
Accuracy @ 20 cm (+/-2 cmH ₂ O)	3.6.1-3			
Accuracy @ 40 cm (+/-2 cmH ₂ O)	3.6.1-3			
Needle movement smooth?	3.6.1-4			
Valve System Checks:				
Pressure greater than 60 cmH ₂ O?	3.6.2-1			
Pressure less than 80 cmH ₂ O?	3.6.2-2			
Maximum pressure set to 40 cmH ₂ O	3.6.2-3			
PIP reset to 20 cmH ₂ O	3.6.2-4			
Additional Comments:				

4. ASSEMBLY DIAGRAMS

4.1 F&P Neopuff T-piece Resuscitator (Post June 2010)

This F&P Neopuff module contains a sealed valve assembly that can not be serviced in the field. If a faulty valve occurs, the entire panel and valve assembly must be replaced.

4.1.1 Assembly Diagram

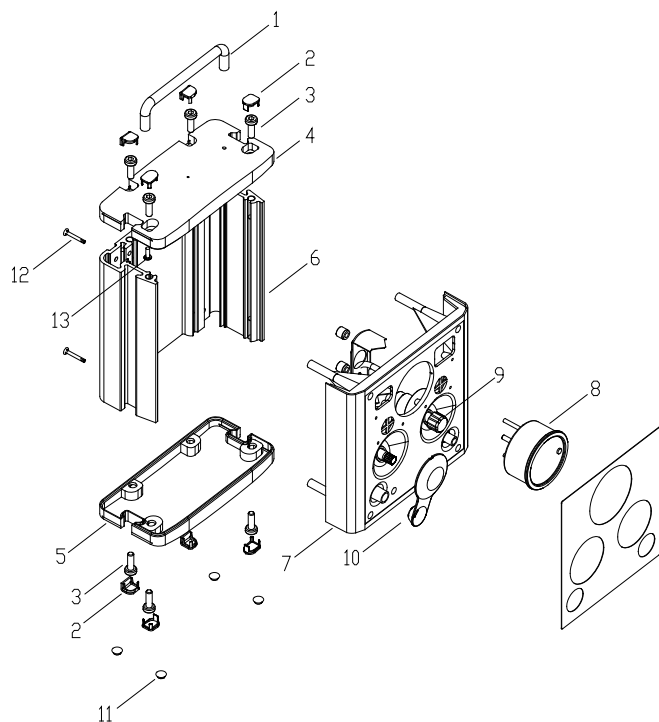

4.1.2 Parts List

UNITS MANUFACTURED POST JUNE 2010			
#	Description	Part Number	Reqd
1	Handle Neopuff Spare	043043976	1
2	Plug (set of four)	693040706	2
3	Screw M8x20	614040309	8
4	End cap (upper)	043042565	1
5	End cap (lower)	043042564	1
6	Back cover	641040816	1
7	Model specific panel and valve assembly	(see table in section 4.1.3)	1
8	Manometer kit	043040841	1
9	Cap Valve Neopuff Spare (Blue)	043043977	1
10	Cover, maximum pressure relief valve	043041057	1
11	Foot	693041436	4
12	Screw #8x1" Csk	616050011	4
13	Screw M4x8 Pan hd (handle attachment)	614040117	2

4. ASSEMBLY DIAGRAMS continued

4.1.3 Spares Kit

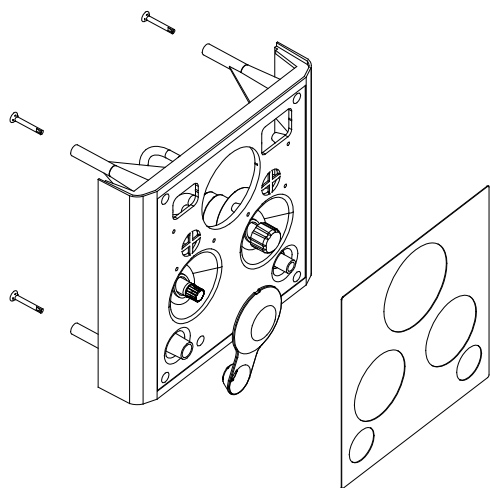

NOTE: All RD900 units manufactured from May 1999 can accommodate the above spares kit.

Kit ID	Included Part No.	Included Part ID product code to be added
Fascia and valve assem BLUE-SYM RD061	043043595	Fascia & Valve Assy Blue SYM
	43043977	Cap Valve Neopuff Spare (Blue)
	43041057	Cover, maximum pressure relief valve
	616050011	Screw #8x1" Csk
Fascia and valve assem BLUE- EN RD062	043043596	Fascia & Valve Assy Blue EN
	43043977	Cap Valve Neopuff Spare (Blue)
	43041057	Cover, maximum pressure relief valve
	616050011	Screw #8x1" Csk
Manometer kit RD065	043040841	Manometer Kit
Endcap kit (Upper) RD063	43043976	Handle Neopuff Spare
	693040706	Plug (set of four)
	614040309	Screw M8x20
	43042565	End cap (upper)
Endcap kit (Lower) RD064	614040117	Screw M4x8 Pan hd (handle attachment)
	693040706	Plug (set of four)
	614040309	Screw M8x20
	43042564	End cap (lower)
Trim Kit RD066	693041436	Foot
	614040309	Screw M8x20
	616050011	Screw #8x1" Csk
	43043977	Cap Valve Neopuff Spare (Blue)
	43041057	Cover, maximum pressure relief valve
	693040706	Plug (set of four)
	693041436	foot

5. MOUNTING OPTIONS

Impact to the F&P Neopuff T-piece Resuscitator, caused by rough handling or the unit being dropped, can damage the valve system and produce irregular resuscitation pressures.

To help prevent any impact to the device, Fisher & Paykel Healthcare recommends the use of one of the mounting systems shown below.

5.1 900RD301 Side-Mounting Block, 900MR170 C-Clamp, 900MR030 Pole Bracket

The 900RD301 Side Mounting Block fits into the dovetail slot on the side of the T-piece Resuscitator. The 900RD301 may then be connected to a 17 to 40 mm pole using either the 900MR170 C-Clamp or 900MR030 Pole Bracket.

Mounting Option	Parts to order	
	Mounting Block	Bracket
Quick disconnect (C-Clamp)	900RD301, RD050-01	900MR170
Permanent Pole Bracket	900RD301, RD050-01	900MR030
Rail mount	900RD301, RD050-01	900MR088

Refer to UI provided with specific mounting solutions for instruction on installation with the Neopuff.

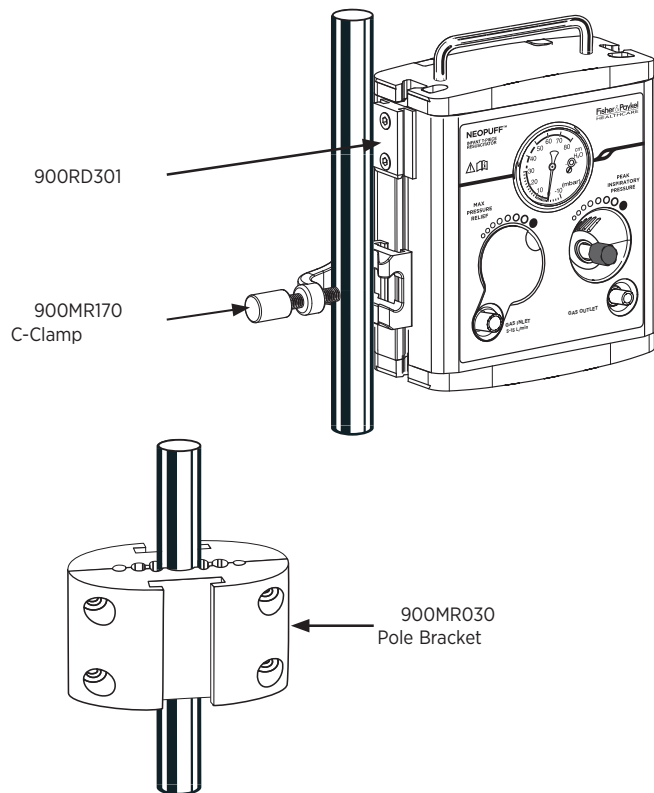

5.2 900MR088 Rail Bracket

For mounting the F&P Neopuff T-piece Resuscitator centrally on standard rails (2.5 to 5.5 cm x 1 cm / 0.98 to 2.17" x 0.39"). Also requires RD050-01.

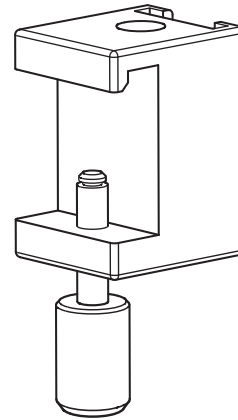

5.3 RD050-01 Pole and Rail Central Mount

For mounting the F&P Neopuff T-piece Resuscitator centrally on a pole or on standard rails (2.5 to 5.5 cm x 1 cm / 0.98 to 2.17" x 0.39"), a central mounting block can be affixed to the back of the unit by removing the four plastic plugs from the rear panel. The unit will then fit the F&P bracket and clamps.

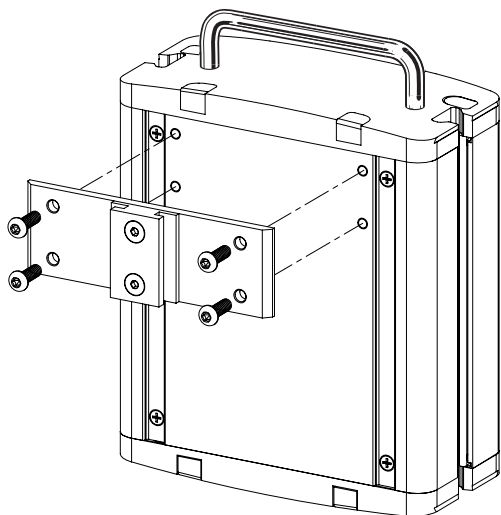

For more information please contact
your local Fisher & Paykel Healthcare representative

Rx only

185041597 REV P EN © 2022 Fisher & Paykel Healthcare Limited

 Fisher & Paykel Healthcare Ltd, 15 Maurice Paykel Place, East Tamaki, Auckland 2013, PO Box 14 348 Panmure, Auckland 1741, New Zealand Tel: +64 9 574 0100 Email: info@fphcare.co.nz Web: www.fphcare.com

 **Australia (AU)** (Sponsor) Fisher & Paykel Healthcare Pty Ltd, 19-31 King Street, Nunawading, Melbourne, Victoria 3131. Tel: +61 3 9871 4900 **Brazil (BR)** Fisher & Paykel do Brasil, Rua Sampaio Viana, 277 cj 21, Paraíso, 04004-000, São Paulo – SP, Brazil Tel: +55 11 2548 7002 **China (CN)** 代理人/售后服务机构:费雪派克医疗保健 (广州) 有限公司, 广州高新技术产业开发区科学城科丰路31号G12 栋301号 电话: +86 20 32053486 **France (FR)**  Fisher & Paykel Healthcare SAS, 10 Av. du Québec, Bât F5, BP 512, Villebon-sur-Yvette, 91946 Courtaboeuf Cedex, France Tel: +33 1 6446 5201 Email: c.s@fphcare.fr **Germany (DE)** Fisher & Paykel Healthcare GmbH, Wiesenstrasse 49, 73614 Schorndorf, Germany Tel: +49 7181 98599 0 **Hong Kong (HK)** Tel: +852 2116 0032 **India (IN)** Tel: +91 80 2309 6400 **Japan (JP)** Tel: +81 3 5117 7110 Fax: +81 3 5117 7115 **Korea (KR)** Tel: +82 2 6205 6900 **Mexico (MX)** Tel: +52 55 9130 1626 **Poland (PL)** Fisher & Paykel Healthcare Poland Sp. z o.o., Pl. Andersa 7, 61-894 Poznań, Poland Tel: +48 664 846 464 **Russia (RU)** Tel: +7 495 782 21 50 **Switzerland (CH)**  Fisher & Paykel Healthcare GmbH, Säntisstrasse 2, 9501 Wil / SG, Switzerland Tel: 0800 83 47 63 **Taiwan (TW)** Tel: +886 2 8751 1739 **Turkey (TR)** İthalatçı Firma: Fisher Paykel Sağlık Ürünleri Ticaret Limited Şirketi, İletişim Bilgileri: Ostim Mahallesi 1249. Cadde No:6, Yenimahalle, Ankara, Türkiye 06374, Tel: +90 312 354 34 12 **UK (GB)**  Fisher & Paykel Healthcare Ltd, Unit 16, Cordwallis Park, Clivemont Road, Maidenhead, Berkshire SL6 7BU, UK Tel: 0800 132 189 **USA (US)/Canada (CA)** Tel: 1800 446 3908 or +1 949 453 4000

Austria (AT) Tel: 0800 29 31 23 **Benelux (BE NL LU)** Tel: +31 40 216 3555 **Denmark (DK)** Tel: +45 70 26 37 70 **Finland (FI)** Tel: +358 9 251 66 123 **Ireland (IE)** Tel: 1800 409 011 **Italy (IT)** Tel: +39 06 7839 2939 **Norway (NO)** Tel: +47 21 60 13 53 **Spain (ES)** Tel: +34 902 013 346 **Sweden (SE)** Tel: +46 8 564 76 680