



Use and Care Guide

for Patients and Caregivers



Intellectual property information

Fisher & Paykel Healthcare products:

F&P, myAirvo, AirSpiral, Optiflow, Optiflow Junior, InfoSmart, InfoUSB, and Wigglepads are trademarks of Fisher & Paykel Healthcare Limited.

For patent information refer to: www.fphcare.com/ip

For more information, please contact your local Fisher & Paykel Healthcare representative.

Compatible third-party products:

Nonin



Nonin™, Xpod®, PureLight®, PureSAT®, FlexiWraps®, Flexi-Form® are trademarks of Nonin Medical Inc.

For patent information refer to: www.nonin.com

Using any sensors other than Nonin-branded PureLight® sensors with the Nonin Xpod USB connector may result in inaccurate performance (of the myAirvo™ 3 and/or Nonin products) and will void the Nonin product warranty.

Before you start

- This user manual is for patients and healthcare professionals for use with the myAirvo™ 3. Patients should only use the myAirvo 3 under the care of a healthcare professional. Take care to follow their instructions carefully. Ask for more information if anything is not clear or you are uncertain about how to use your myAirvo 3 properly.
- While the information presented here is believed to be accurate, it is not a substitute for the professional advice of your physician.
- Read through these instructions carefully before using your myAirvo 3. Take note of any warnings and cautions, which will help you use your myAirvo 3 safely.
- If any device or accessory label is damaged or unreadable, contact your healthcare provider for a replacement.
- Your healthcare provider will set up your myAirvo 3 so that it is ready for your therapy as soon as it is turned on. Your physician will help you understand your therapy and how it can help you.

Throughout these instructions you will find warnings and cautions marked with the symbols shown below. Some will be familiar already but take care to understand all of these important points. Seek clarification from your healthcare provider if any are unclear. We want you to use your myAirvo 3 safely. Download this user manual online and watch training videos on the myAirvo website at: www.fphcare.com/myairvo3

Conventions used in this manual

Warning

A warning is a potential hazard which, if not avoided, could result in death or serious injury to you or a family member.

Caution

A caution is a potential hazard which, if not avoided, may result in minor or moderate injury to you or a family member.

Note

Notes emphasize information that is important for using the myAirvo 3 correctly.

Contents

1. Introducing the myAirvo 3	4
1.1 Intended use	4
1.2 Indications for use	4
1.3 Contraindications	4
2. Safety information	5
2.1 General	5
2.2 Reprocessing	8
3. myAirvo 3 and accessories	9
4. Using the myAirvo 3	11
4.1 Set up the myAirvo 3	11
4.2 Prepare the water chamber	11
4.3 Connect the AirSpiral heated breathing tube	13
4.4 Pulse oximeter	13
4.5 Switch on your myAirvo 3	13
4.6 Connect oxygen supply	15
4.7 Connect the patient interface	16
4.8 Patient consent	17
4.9 Answering the profile and outcome questionnaires	18
4.10 Changing consent preferences	20
4.11 Answering the patient diary questions	20
4.12 Screen overview	22
4.13 During therapy	23
4.14 Stopping therapy	27
5. After use: caring for your myAirvo 3	28
5.1 Drying Mode	28
5.2 Daily care	29
5.3 Weekly care	30
5.4 Timetable for changing accessories	32
5.5 Air filter replacement	33
5.6 Servicing	34
5.7 Software update	34
5.8 Storage	34
6. Sharing your therapy data	35
6.1 Your personal data	35
6.2 Cellular modem	35

6.3 Loading data onto the myAirvo 3 InfoUSB.....	36
7. Viewing your therapy data	38
8. Traveling with myAirvo 3	39
9. Alarms	40
9.1 Alarm priority	40
9.2 Audible information signals	40
9.3 Viewing alarm details.....	41
9.4 Device alarms	42
9.5 Checking the alarm system	44
10. Pulse oximetry	45
10.1 Set up the pulse oximeter	47
10.2 Using the pulse oximeter.....	49
10.3 After use	50
10.4 Troubleshooting	50
10.5 Description of measurements	51
11. Advanced settings	53
11.1 Using the touchscreen	53
11.2 Touch lock	54
11.3 Therapy settings.....	55
12. Parts and accessories	57
12.1 Patient consumables	57
12.2 Replacement parts and accessories	58
12.3 Pulse oximeter sensors and accessories	58
13. Specifications	60
13.1 Oxygen fraction.....	63
13.2 Standards and approvals.....	63
13.3 Device disposal instructions	64
13.4 Disposal of accessories, spare parts and packaging.....	64
14. Glossary	65
14.1 Status icons	65
14.2 Symbols	66
14.3 Terms	67
Appendix 1. Humidification behavior during battery operation	68

1. Introducing the myAirvo 3

The myAirvo 3 provides humidified delivery of high flow respiratory gases. These respiratory gases may be supplemented with additional oxygen, if required. A built-in oxygen analyzer directly monitors the concentration of oxygen in the respiratory gas delivered. The respiratory gases are delivered for breathing using a selection of nasal and tracheostomy patient interfaces. The myAirvo 3 can monitor SpO₂ and pulse rate using an optional pulse oximeter accessory (see myAirvo 3 Technical Guide for more information).

1.1 Intended use

The myAirvo 3 is a respiratory support device intended to provide warmed and humidified respiratory gases to patients.

1.2 Indications for use

The myAirvo 3 is for the treatment of spontaneously breathing patients, infant to adult, who would benefit from receiving high flow warmed and humidified respiratory gases. This includes patients who have had upper airways bypassed. The flow may be from 2 – 60 L/min depending on the patient interface. The myAirvo 3 is for patients in homes and long-term care facilities.

1.3 Contraindications

Contraindications are therapy-specific. Refer to instructions of patient interfaces and/or tube and chamber kits for therapy-specific contraindications.

2. Safety information

The myAirvo 3 and accessories are to be operated by, or under the supervision of, qualified personnel only. Read this manual, particularly all warnings, cautions and notes, and the instructions for use supplied with all accessories before using the myAirvo 3.

2.1 General

Side effects

Side effects are therapy-specific. Refer to instructions of patient interfaces and/or tube and chamber kits for therapy-specific side effects. Refer to compatible accessories instructions for correct usage.

Warnings

- The myAirvo 3 is not intended for life support. Do not use myAirvo 3 on patients who cannot tolerate a brief interruption of therapy.
- Appropriate patient monitoring must be used at all times. Contact your healthcare provider if you have any concerns.
- Continuous SpO₂ monitoring should be used on patients who would desaturate significantly in the event of disruption to their oxygen supply.
- Delivery of respiratory gases may generate positive airway pressure. This must be considered where positive airway pressure could have adverse effects on a patient. To avoid serious injury, appropriately monitor the patient for risk factors of airway and lung pressure injury.
- Loss of therapy will occur if the wall power supply is turned off or disconnected and the optional battery is depleted or not installed.
- Do not use any patient consumables, accessories or replacement parts that are not listed in the myAirvo 3 User Manual, or the myAirvo 3 Technical Guide. Incompatible consumables, parts or accessories could affect the quality of therapy, injure the patient, decrease electromagnetic immunity or increase electromagnetic emissions.
- Use only patient interfaces and heated breathing tubes specified in this manual to prevent disconnection during use, especially when moving the myAirvo 3.
- Do not use anti-static or electrically conductive hoses or tubing with the myAirvo 3.
- Do not start or operate the myAirvo 3 unless the device setup, including all accessories, is verified to be correct.
- Carefully route accessories, cords and cables, including the breathing tube, to reduce the possibility of patient entanglement or strangulation.
- Keep the air openings free of lint, dust, hair and other foreign objects.
- Excess pet hair in the home may block the air filter and compromise performance. Check the air filter regularly and replace if there is a build-up of debris.
- Take care that water does not spill from the water chamber into the myAirvo 3 when moving the device.
- Visually inspect the myAirvo 3 and accessories before use and replace if damaged or suspected to be damaged. Using a damaged device or accessories may impair performance and/or compromise safety.
- Do not use accessories beyond the maximum period of use specified in this manual. Exceeding the maximum use period can result in serious injury, including infection.
- Make sure the auditory alarm signal is audible by following the *Checking the alarm system* section instructions to test the alarm before starting patient therapy.

- Do not use a myAirvo 3 on more than one patient without following the disinfection process between patients. Refer to the myAirvo 3 Technical Guide for reprocessing instructions.
- If any device or accessory label is damaged unreadable contact your healthcare provider for a replacement.
- Do not connect the myAirvo 3 to the battery of a battery powered wheelchair, as this may compromise device performance and therapy delivered.
- Do not expose the myAirvo 3 battery to water, fire or excessive heat. Do not crush, disassemble or puncture the battery, or short circuit the connector terminals.
- Do not use the myAirvo 3 as an apnea monitor.
- Do not use the myAirvo 3 for arrhythmia analysis.
- In the event of a battery leaking, do not allow the liquid to come in contact with the skin or eyes. If contact has been made, wash the affected area with copious amounts of water and seek medical advice.
- Seek medical advice immediately if a cell or a battery has been swallowed.
- Changes or modifications unauthorised by FPH could void the user's authority to operate the equipment.
- California residents please be advised of the following pursuant to Proposition 65: This product contains chemicals known to the State of California to cause cancer, birth defects and other reproductive harm. For more information, please visit: www.fphcare.com/prop65

Operating conditions

- Do not use the myAirvo 3 at an altitude or temperature outside the rated range listed in the *Specifications* section of the manual. Using outside of these ranges can compromise the equipment performance which consequently can result in degradation of the health of the patient.
- Do not use the myAirvo 3, or accessories, during defibrillation.
- Do not use the myAirvo 3 in a magnetic resonance imaging (MRI) environment.
- Do not use the myAirvo 3, or accessories during electrocautery.
- Explosion hazard: Do not use the myAirvo 3 in the presence of flammable anesthetics, gases or other flammable substance in combination with air, oxygen-enriched environments, or nitrous oxide.
- Avoid using the myAirvo 3, or accessories, adjacent to, or stacked with, other equipment, which could result in improper operation. If such use is necessary, this equipment and the other equipment should be observed to verify that they are operating normally.

To avoid burns:

- Do not touch the hot surface of the heater plate or chamber base.
- Read all the warnings in the *Connect oxygen supply* section of this manual on pages 15 and 16 before using the myAirvo 3 with oxygen.
- Never operate the myAirvo 3 if:
 - the heated breathing tube has been damaged in any way including holes, tears or kinks,
 - it is not working properly, or
 - water has entered the device.
- Do not restrict ventilation around the myAirvo 3, which may cause it to overheat.
- Do not block the flow of air into the myAirvo 3 by covering or placing the myAirvo 3 on a soft surface (e.g. a bed, sofa, couch or blanket). Blocking the airflow may interfere with the breathing gas supplied to the patient.
- Do not block the flow of air through the myAirvo 3 or breathing tube.

To avoid electric shock:

- Always remove the pulse oximeter sensor and completely disconnect the pulse oximeter before bathing the patient.
- Before cleaning, always turn off the myAirvo 3 and disconnect from the wall power supply.
- Do not store or use the myAirvo 3 and accessories where it can fall or be pulled into water. Stop using the myAirvo 3 immediately if water has entered the case and disconnect the power cord from the wall power supply.
- Never operate the myAirvo 3 if it has, or is suspected of having:
 - been dropped or damaged,
 - a damaged power cord or plug, or
 - been dropped into water.

Refer to the myAirvo 3 Technical Guide to replace a damaged power cord.

- Do not remove the power cord from the myAirvo 3 unnecessarily. Grip the plug, and not the cable, if removing the power cord. Do not pull on the cable.
- Do not adjust, repair, open, disassemble or modify the myAirvo 3, pulse oximeter equipment, or accessories except as described in this user manual or the myAirvo 3 Technical Guide. Return the myAirvo 3 to your Fisher & Paykel Healthcare representative for servicing, if necessary.
- Do not touch the patient at the same time as any conductive parts of the device, such as USB ports.

To avoid choking, or inhalation of a foreign object:

- Do not operate the myAirvo 3 unless the air filter is correctly installed.
- Never drop or insert any object into any opening or tube.
- Make sure the myAirvo 3 is level and positioned lower than the patient's head during use.

Cautions

- When operating in battery mode, a Low Battery alarm will be displayed at less than 35% charge, and a Critically Low Battery alarm will be displayed at less than 20% charge.
- Connect the myAirvo 3 to the wall power supply promptly after a Low Battery alarm to avoid loss of therapy when the device shuts down.
- Make sure the myAirvo 3 humidifier is placed at least 20 cm (8") from your body when turned on to reduce exposure to radio-frequency energy from the built-in cellular modem.
- The amount of therapy time available after the Low Battery alarm will vary depending on the age of the battery module. All batteries lose capacity with age.

Notes

- Changes or modifications not expressly approved by Fisher & Paykel Healthcare, voids the user's authority to operate the device.
- The built-in oxygen analyzer uses ultrasonic measurement technology. It does not require in-field calibration.
- Notice to User: If a serious incident has occurred while using this device, please inform your local Fisher & Paykel Healthcare representative and Competent Authority in your country.

2.2 Reprocessing

Warnings

- When using the myAirvo 3 with multiple patients (in a long-term care facility, for example) follow hospital infection control guidelines to reduce risk of cross-contamination. The myAirvo 3 is not a sealed system.
- Do not submerge the myAirvo 3 or accessories in any cleaning solution or attempt to sterilize by autoclave, irradiation, steam, gas, ethylene oxide or any other method. This will seriously damage the device. Any device or accessory so treated should be discarded. It will never work properly again.
- Do not use any solutions, suspensions, emulsions, anesthetic or respirable gases that are not identified in this user manual. They may not be compatible with the patient consumables, device or accessories.
- Use only genuine Fisher & Paykel Healthcare replacement battery modules to prevent damage to the myAirvo 3, excess temperature, fire or explosion.
- Do not dispose of the battery in a fire; it could catch fire and explode.
- Dispose of batteries in accordance with local guidelines.

3. myAirvo 3 and accessories

This section shows the myAirvo 3 system and compatible accessories.

myAirvo 3 flow-generator and humidifier

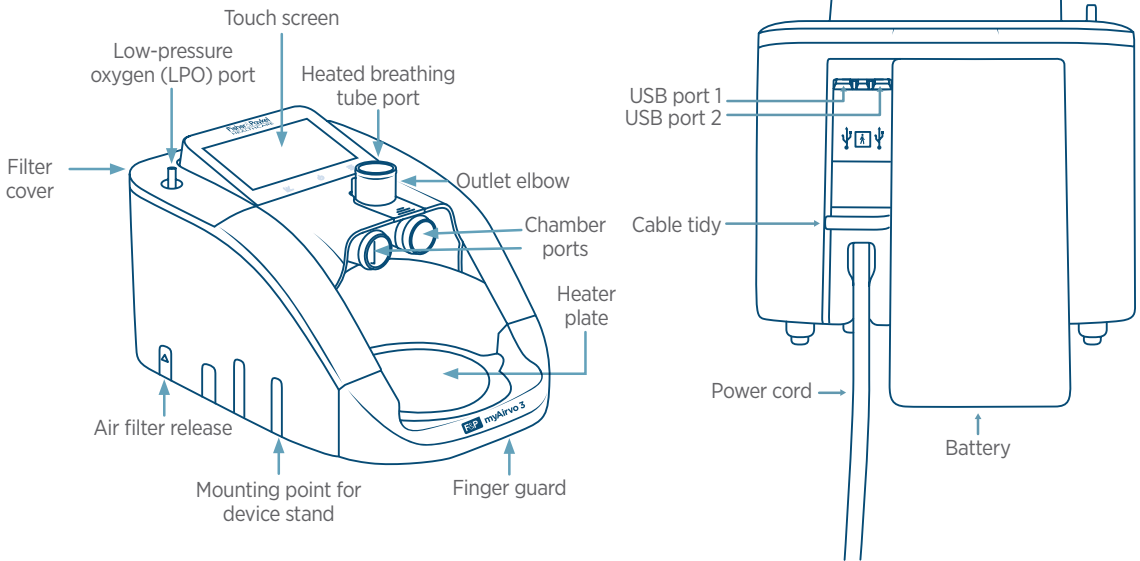

Compatible accessories



Nasal interface



Optiflow+

- | | | |
|---------|--------------|--------------|
| OPT942E | MYOPT9SMALL | MYDUETSMALL |
| OPT944E | MYOPT9MEDIUM | MYDUETMEDIUM |
| OPT946E | MYOPT9LARGE | MYDUETLARGE |



Optiflow Junior 2

- OJR416HM
OJR418HM

Tracheostomy interface Mask interface adapter

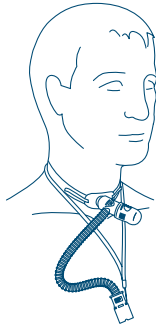

Optiflow+

- MYOPT9TRACHE
OPT970E

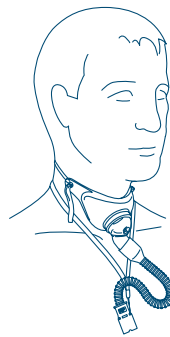

Optiflow+

- MYOPT9MASK
OPT980E

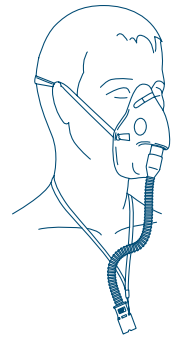

myAirvo 3 Set up

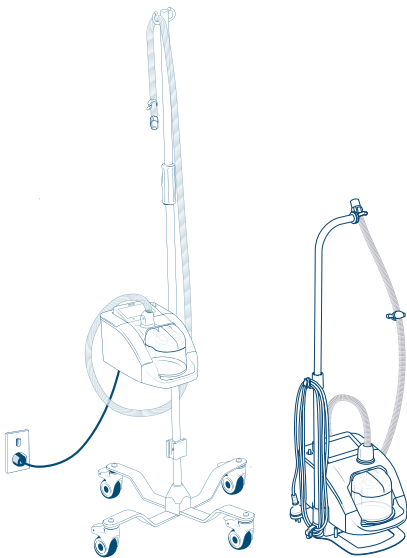

Reusable Chamber

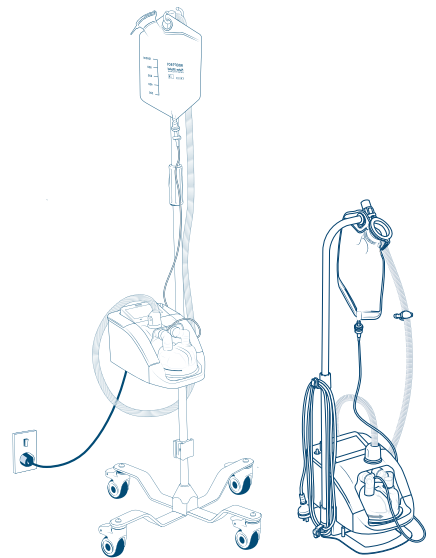
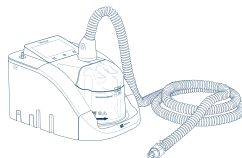

Auto-fill Chamber

4. Using the myAirvo 3

At the start of each therapy session you will need to prepare your myAirvo 3.

4.1 Set up the myAirvo 3

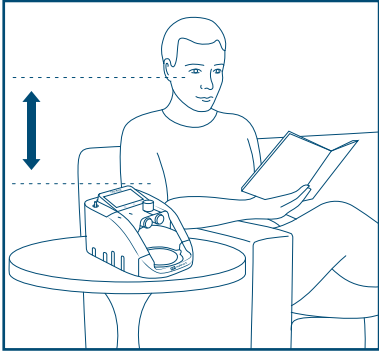

Before starting your therapy, you will need to ensure that the device is level and that the top of the humidifier is below head-height during therapy.

If your device does not have the optional battery installed, you can place the myAirvo 3 directly on the floor, a low shelf or on a device stand. If your device has the optional battery installed, you will need to use a device stand to ensure the device is level. Refer to myAirvo 3 Set up on section 3.

Place the myAirvo 3 beside your bed or the chair where you will use the device.

Warnings

- Do not place the myAirvo 3 above head height. Placing the myAirvo 3 above head height could allow water to enter the breathing tube, which might be inhaled and cause choking or other injury.
- Do not cover the myAirvo 3 or place it near a heater (within 1 m, 3'). For example, covering the device with a blanket or exposing the device to a radiant heater or fireplace may cause the device to overheat and malfunction.
- Do not move the myAirvo 3 while using therapy, even if using the Mobile Pole Stand.
- Do not cover or position next to materials that can block the gas intake, thereby interfering the patient therapy.

4.2 Prepare the water chamber

The respiratory gases are warmed and humidified inside the water chamber.

There are two types of water chamber available for the myAirvo 3, the:

- Reusable Chamber, and
- Auto-fill Chamber.

Follow the steps in the user manual included with your chamber or tube and chamber kit to set up your chamber.

The table below show approximately how long a full water chamber or Water Bag will last on the myAirvo 3 at different flow rates.



Reusable Chamber

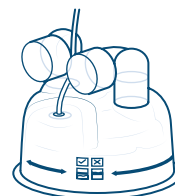

Auto-fill Chamber

myAirvo 3 water use time in hours		
Flow, L min ⁻¹	Reusable Chamber (MYAIRVOCHAMBER1)	Auto-fill Chamber and Water Bag (MYAIRVOKIT1 and 900PT401)
	(560 mL)	(1000 mL)
2	72	129
5	33	60
10	17	31
15	11	21
20	9	16
25	7	12
30	6	10
35	5	9
40	4.5	8
45	4	7
50	3.5	6.5
55	3	5.5
60	3	5

Warnings

- Take care not to burn yourself when removing the water chamber or moving the myAirvo 3. The water in the chamber and the bottom of the chamber will be hot during and after use.
- Do not turn on the myAirvo 3 without the water chamber in place.
- Keep the water chamber level when moving the myAirvo 3. Water can spill inside and damage the myAirvo 3 if you tilt the device while the chamber contains water.
- Do not use the auto-fill water chamber if it has been dropped or allowed to run dry. This could lead to the chamber overflowing.
- The water in the chamber and the bottom of the chamber will be hot during use. Take care not to burn yourself when removing the chamber or moving the myAirvo 3.
- Do not use the auto-fill chamber if the water level rises above the maximum water level line. This may lead to water entering the patient's airway.

Cautions

- Use only distilled water with the auto-fill chamber. Adding other substances can damage the humidifier and adversely affect the therapy delivered.
- Use only drinkable quality water or distilled water in the reusable chamber. Adding other substances can damage the humidifier and adversely affect the therapy delivered.

4.3 Connect the AirSpiral heated breathing tube

The AirSpiral Tube carries the breathing gases generated by your myAirvo 3 to your nasal, tracheostomy, or mask interface adapter. It is warmed to help prevent condensation building up inside the breathing tube.

Only use compatible AirSpiral Tubes that are specified in the patient consumables list.

Follow the steps in the user manual included with your AirSpiral Tube or AirSpiral Tube and Chamber Kit to set up your AirSpiral Tube.

Warnings

- Do not allow the heated breathing tube to remain in direct contact with your skin for long periods of time to avoid the risk of burns. Your healthcare provider will assess the conditions for safe contact, such as duration and skin condition.
- Do not cover or heat any part of the heated breathing tube. Covering or heating the breathing tube (e.g. with a blanket, insulating sleeve, bedcovers, heater or incubator) can affect the quality of the therapy, or could result in a serious injury.

Caution

Keep the heated breathing tube away from electrical monitoring leads (e.g. EEG, ECG/EKG, EMG, pulse oximeter) to reduce the risk of interference with the signal monitored.

4.4 Pulse oximeter

Follow the instructions in the *Pulse oximetry* section if your healthcare provider has supplied you with a pulse oximeter to monitor your blood-oxygen saturation (SpO₂).

4.5 Switch on your myAirvo 3

Make sure you have the myAirvo 3 in a location where you don't need to move it when starting therapy.

If using the Mobile Pole Stand, lock the wheels to prevent the myAirvo 3 from moving.

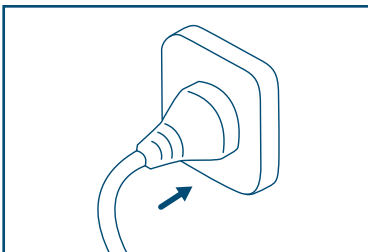

Plug the myAirvo 3 power cord into a power outlet. Position the myAirvo 3 so that the power cord connection to the wall power supply is easily accessible and can be disconnected if necessary.

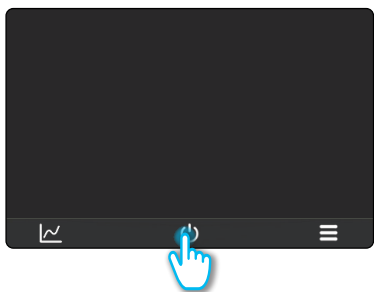

Switch on the myAirvo 3 by holding down the Power Button for 2 seconds.

Warnings

- Make sure the myAirvo 3 is dry before plugging it into the wall power supply to avoid a potential electric shock.
- Do not use the myAirvo 3 if the device, power cord or any accessories are damaged, deformed or cracked. A damaged cord could give you a fatal electrical shock.
- Ensure you will not become entangled in the power cord, or any extension cords, while using the myAirvo 3 to avoid choking or strangulation.
- Do not turn on the myAirvo 3 without the water chamber in place.
- Loss of therapy will occur if the wall power supply is turned off or disconnected and the optional battery is depleted or not installed.

Note

To ensure responsiveness, keep the myAirvo 3 touchscreen clean and dry. Performance may be reduced if the screen is allowed to become wet.

4.6 Connect oxygen supply

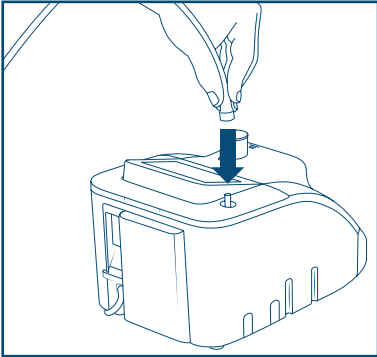

If you have been prescribed supplementary oxygen, connect your oxygen supply while the myAirvo 3 is warming up. Connect the tube from your oxygen supply to the oxygen port on the top of the myAirvo 3. Push the oxygen tube firmly onto the connector.

Follow the instructions provided by your healthcare provider to turn on your oxygen supply and select the prescribed flow rate. It is important that you use both the oxygen flow rate and myAirvo 3 flow rate as prescribed by your physician. Do not change the prescribed settings without consulting your healthcare provider.

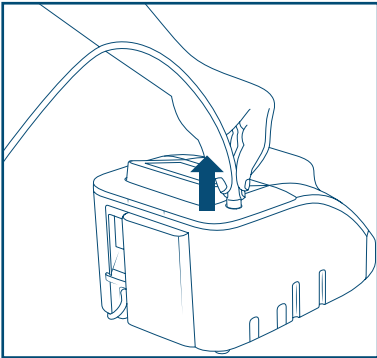

If a **FiO₂ High** or **FiO₂ Low** alarm occurs, check that the oxygen tube is properly connected, and you have set up the oxygen source correctly. Contact your healthcare provider if the problem persists.

Turn off and disconnect the oxygen supply when your therapy is finished.

Warnings

- Do not lubricate fittings, connections, tubing, or other accessories of the equipment to avoid the risk of fire and burns.
- Make sure the myAirvo 3 is turned on before connecting oxygen.
- You must take special care when using oxygen to reduce the risk of fire:
 - Do not use oxygen while smoking, near sparks or open flames.
 - Keep all ignition sources away from the myAirvo 3 when using oxygen. This includes matches, lighters, gas cookers and electric motors.
 - Make sure ventilation around the myAirvo 3 is not restricted.
- A spontaneous and violent ignition may occur if oil, grease or greasy substances contact oxygen under pressure. Keep these substances away from all oxygen equipment.
- There is a risk of fire associated with oxygen enrichment during oxygen therapy. Do not use the equipment or accessories near sparks or open flames.
- Oxygen makes it easier for a fire to start and spread. Do not leave the nasal cannula or mask on bed coverings or chair cushions, if the device is turned on, but not in use; the oxygen will make the materials more flammable. Turn the device off when not in use to prevent oxygen enrichment.
- It is the responsibility of the responsible organization to ensure that the oxygen source is compatible with the rated range of pressure, flowrate and oxygen concentration as marked on the equipment and indicated in the instructions for use as this can affect the performance of the equipment or pipeline system that can consequently result in serious deterioration of health.

- Smoking during oxygen therapy is dangerous and is likely to result in facial burns or death. Do not allow smoking or open flames within the same room as the equipment or any oxygen-carrying accessories. If the patient intends to smoke, always turn the equipment off, remove the cannula and leave the room where the equipment is located. If unable to leave the room, wait 10 minutes after the equipment has been turned off.
- Do not connect oxygen with a flow rate exceeding 15 L/min to the oxygen inlet port on the myAirvo 3.
- Oxygen must only be added through the inlet port on the top of the filter. The filter must be properly inserted into the filter slot.
- The oxygen concentration delivered can be affected by changes to the myAirvo 3 flow rate setting, supplementary oxygen flow rate, patient interface or any blockages in the airpath.
- Make sure the air filter is installed correctly before connecting supplementary oxygen.
- Connect only pure oxygen gas or oxygen supplied by an oxygen concentrator to the oxygen inlet port on the myAirvo 3 as directed by a healthcare provider. The myAirvo 3 may display an incorrect oxygen concentration if any other gas or mixture of gases is connected, or the myAirvo 3 is not correctly configured for the oxygen supply connected.
- Only use lotions and/or salves that are labelled as oxygen-compatible to avoid the risk of fire and burns.
- Oxygen must be turned off before the myAirvo 3 is turned off so that oxygen does not build up inside the device.

4.7 Connect the patient interface

Your healthcare provider will work with you to select the correct patient interface and show you how to adjust it for a comfortable fit. Talk with your physician if you have any questions or concerns.

Follow the steps in the user manual included with your interface to connect to your AirSpiral Tube.

Some patient interfaces, such as the Optiflow Junior 2 Nasal Cannula, restrict the range of flow rates that can be delivered to the patient. Refer to the patient interface user manual for details.

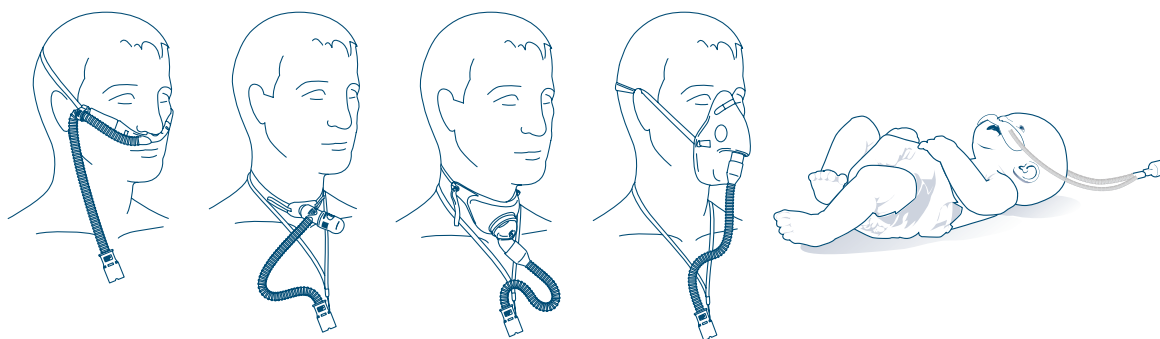

Warnings

- Only use patient interfaces compatible with the myAirvo 3. Refer to the patient consumables table for a list of compatible patient interfaces.
- Ensure a sufficient intended leakage between the breathing system and the patient to allow the patient to exhale

- Do not use sealed patient interfaces with Optiflow high flow therapy, to avoid the risk of suffocation or barotrauma

4.8 Patient consent

The myAirvo 3 will ask if you wish to share your data with Fisher & Paykel Healthcare, to support future product improvements. Your participation is voluntary. You can opt in or out at any time by changing your Consent Preferences in the Device Info menu.

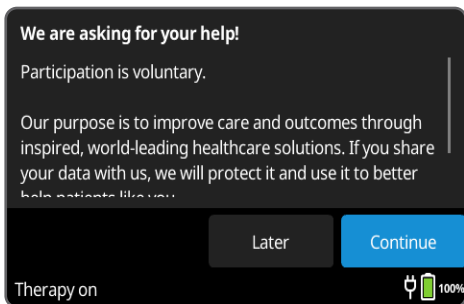

When prompted, tap **Continue** to view the consent forms or **Later** to skip this step and proceed to therapy.

The prompt will no longer appear on startup if **Later** has been selected 3 times.

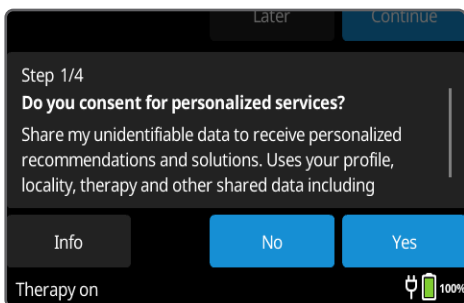

If **Continue** is selected, you will be taken through three consent forms:

- personalized services
- support development
- research opportunities.

For each consent form, touch the screen and swipe up or down to view all the information.

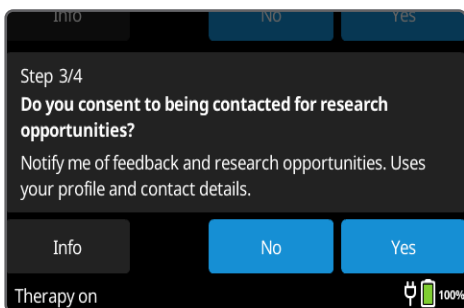

Tap the **Info** button to view the Privacy Notice.

Tap **No** if you do not give consent or **Yes** if you give consent.

You will have the opportunity to review and change your selections before submitting your responses to Fisher & Paykel Healthcare.

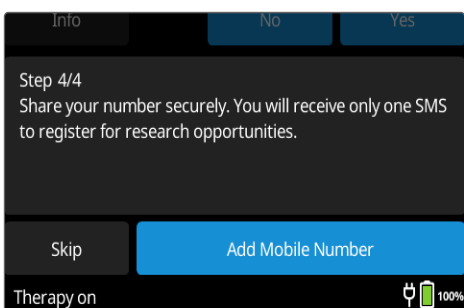

If you consent to being contacted for research opportunities, the myAirvo 3 device will prompt you to add your mobile number.

Tap **Skip** if you do not wish to provide your mobile number.

Tap **Add Mobile Number** if you wish to provide your mobile number.

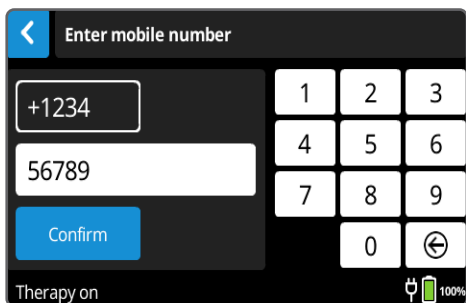

Tap the numbers on the screen to enter your country code and mobile number.

Tap **Confirm** once you have entered your country code and mobile number.

If you do not wish to provide your mobile number, tap the back button  to return to the previous screen.



Review your answers and if you are happy, tap **Submit** to send them to Fisher & Paykel Healthcare.

If you would like to change your answers or view more information, please take one of the following actions:

Change consent - Tap the **check box** next to the line you would like to change.

View Privacy Notice - Tap on the consent form you would like to read the privacy notice for.

Edit mobile number - Tap **Edit** next to the mobile number to update it.

Add mobile number - Tap **Add Mobile Number**.

Once you are happy with your answers, tap **Submit** to send them to Fisher & Paykel Healthcare.

To change or update your Consent Preferences at a later time, refer to section 4.10.

4.9 Answering the profile and outcome questionnaires

The myAirvo 3 will prompt you to complete a one-off Profile Questionnaire and a monthly Outcome Questionnaire, if you provided consent to receiving personalized services and/or support development. If you have not provided consent, the myAirvo 3 will not prompt you to complete these.

Profile Questionnaire:

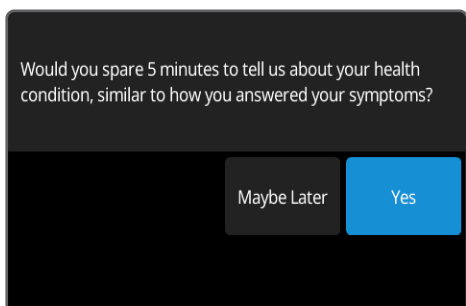

If prompted, tap **Yes** to answer the questions or **Maybe Later** to skip this step and proceed to therapy.

The prompt will no longer appear on startup if **Maybe Later** has been selected 3 times.

Outcome Questionnaire:

Hello, we are interested in how things are going for you. Please answer this short questionnaire about your recent health.

Maybe Later Continue

Compared to last month, how has your health changed?

Much better A little better About the same A little worse Much worse

Back Skip

In the past month, did you make any unplanned health visit?

Physician visit A&E or urgent care visit

In-hospital stay None

Back Skip

Thank you for taking the time to answer these short questions.

Back Finish

If prompted, tap **Continue** to answer the questions or **Maybe Later** to skip this step and proceed to therapy.

The prompt will not appear on startup, for the next 30 days. If **Maybe Later** has been selected 3 times, the prompt will no longer appear.

Answer each question by tapping the button that most closely describes you and your condition.

- Tap **Skip** if you do not want to answer the question.
- Tap **Back** to change your answer to the previous question.

The **Next** button will appear if you select one of the checkbox answers.

Tap **Skip** if you do not want to answer the question.

Once you are happy with your answers, tap the **Finish** button to send your answers to Fisher & Paykel Healthcare.

4.10 Changing consent preferences

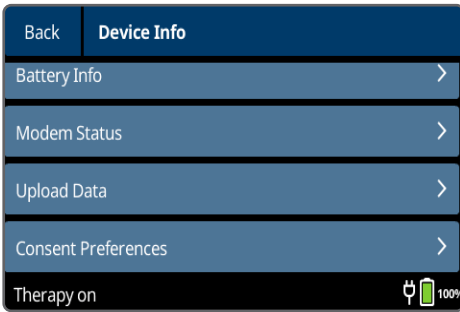

If you would like to change your Consent Preferences, tap  to access the myAirvo 3 menu.

Tap **Device Info**. You may need to swipe up/down to see all the options.

Tap **Consent Preferences**.

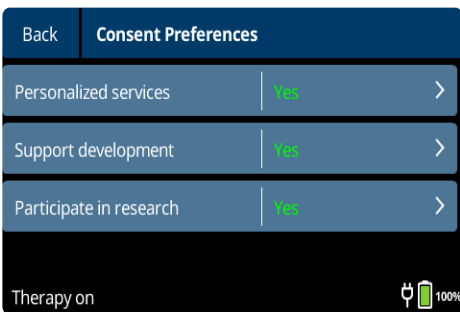

Tap  on the consent form that you would like to change your response for.

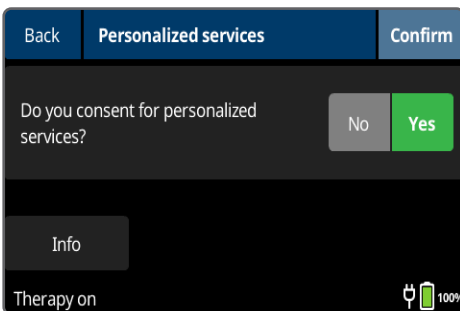

Tap **No** if you do not give consent or **Yes** if you give consent.

To review the Privacy Notice, tap **Info**.

4.11 Answering the patient diary questions

If your healthcare provider has turned on patient diary collection, the myAirvo 3 will prompt you to complete the questions they have selected for you. Not all healthcare providers need this information so myAirvo 3 may skip this step.

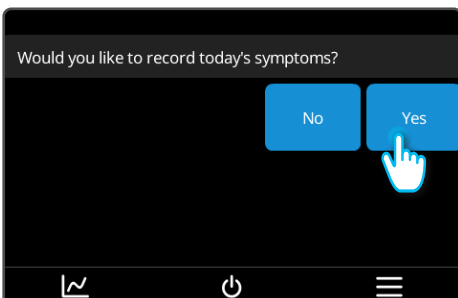

If prompted, tap **Yes** to answer the questions or **No** to skip this step and start therapy.

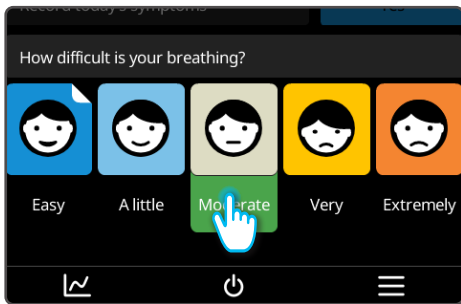

Answer each question by tapping the button that most closely describes your condition.

Work through each question in turn. Your healthcare provider may have selected different questions to the examples shown here.

Your answers are not sent straight away. You will be able to review and change any answer before submitting your responses to your healthcare provider.

The previous question, and your answer, are shown at the top of the screen.

To change your answer to the previous question:

1. Tap your answer shown at the top of the screen
2. Select a new answer.

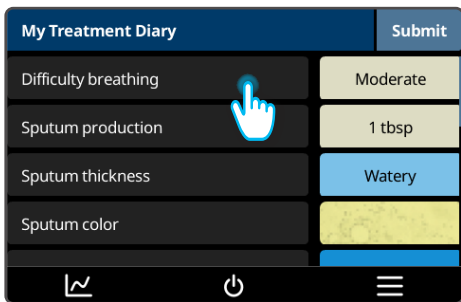
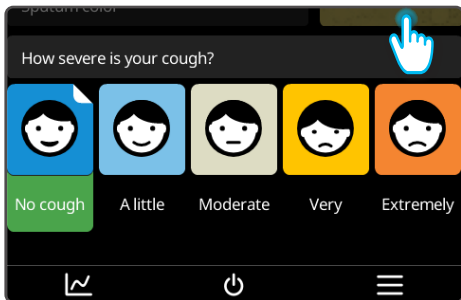

Review your answers after completing all the questions. Make any changes you desire.

- Tap any question to change your answer

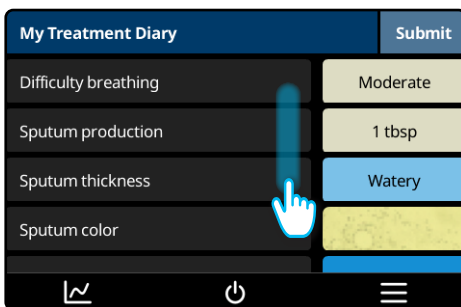

- Touch the screen and swipe up or down to view all the questions and your answers.

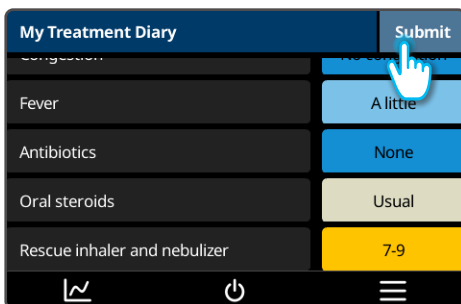

Once you are happy with your answers, tap the **Submit** button to send your responses to your healthcare provider.

Warning

If you are experiencing severe symptoms, contact your healthcare provider directly.

4.12 Screen overview

You will see the home screen when myAirvo 3 is plugged in and turned on. Your healthcare provider will set up your myAirvo 3 with the best settings for your therapy. Most users won't need to change any settings.

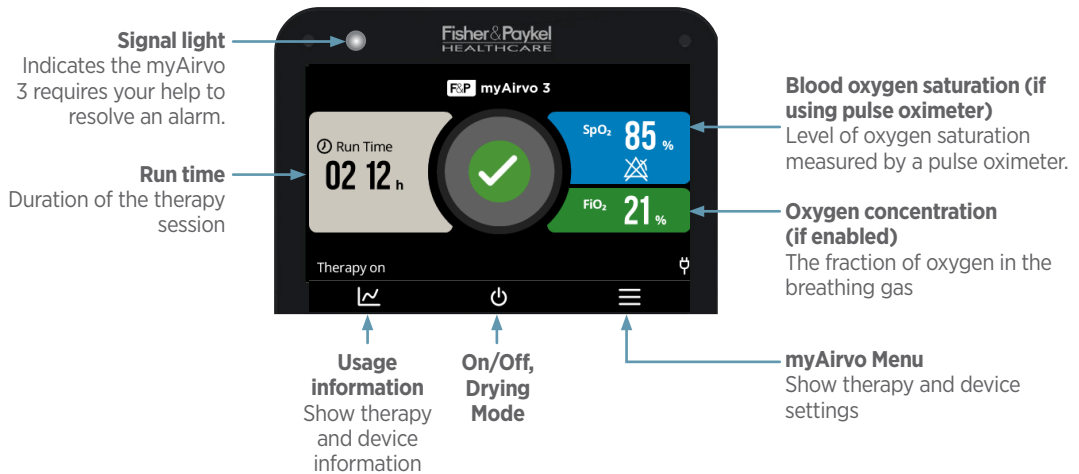

4.12.1 Alarms

You may see an alarm if something unexpected happens. The myAirvo 3 will suggest actions to help you resolve the problem. See [Alarms](#) on page 40 for more help resolving alarms.

Alarms can be silenced for 120 seconds by tapping Audio Pause (🔔 button).

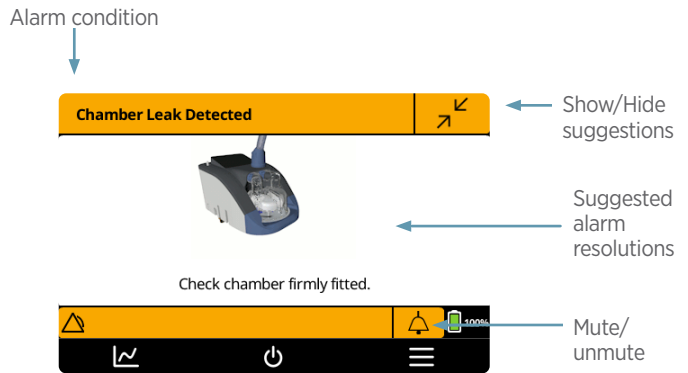

4.12.2 Warming up

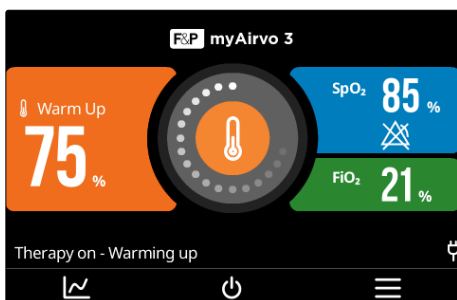

The myAirvo 3 will begin warming and humidifying the breathing gases when it is turned on.

- The warm up symbol is shown on the screen while the myAirvo 3 is warming up.
- The Therapy ON symbol is shown when the myAirvo 3 has finished warming up.



You can start using the device immediately but may find therapy more comfortable when the myAirvo 3 has finished warming up.



The myAirvo 3 will play a short melody when it has finished warming up and display the Therapy ON symbol.

4.13 During therapy

You have completed setting up the myAirvo 3 and your therapy has begun.

The breathing gases may feel warm when you start using the myAirvo 3. This is normal. Just continue to breathe normally. Follow the instructions provided by your physician for the duration and frequency of each therapy session.

4.13.1 Tracking accessory use

The accessory timers help you track when it is time to replace your air filter, patient interface, AirSpiral Tube and chamber kit so you don't exceed the maximum allowed use.

Check the timers while therapy is being delivered. Plan to replace any accessories that have exceeded the maximum allowed use before your next therapy session (if possible). Before starting the next therapy session, reset the timer for any accessory you replaced.

Talk to your healthcare provider about replacement accessories before exceeding the maximum allowed use (see Timetable for changing accessories on page 32).

Checking usage time

View the amount of time your accessories have been used, since the timer was last reset, by:



1. Tap to open the myAirvo menu.

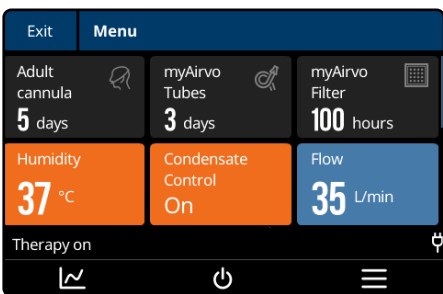

Each tile displays the amount of time an accessory has been used for since it was last replaced, and the timer reset.

The symbol will be displayed when it is time to replace an accessory.

Resetting usage timers

Reset the timer each time you replace a patient interface, air filter or AirSpiral Tube and water chamber kit so you know when it is time to replace them again. To reset a timer when you change an accessory:

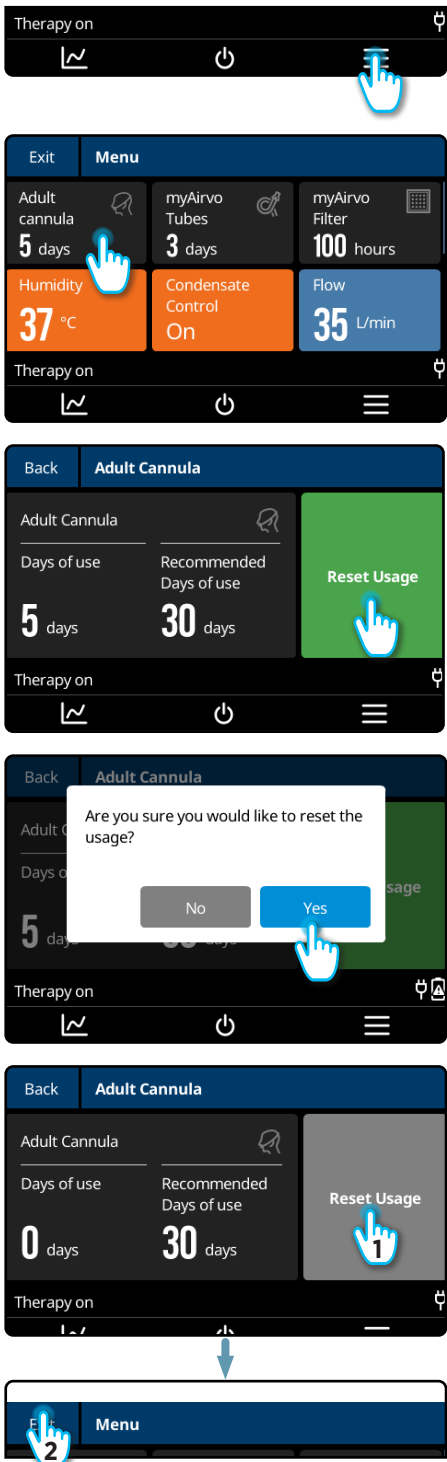

1. Tap **≡** to open the myAirvo menu.
2. Tap the timer tile to show the timer details information.
3. Tap the **Reset usage** button to set the timer back to zero when you start using a new accessory. You can tap **Back** if you change your mind and no longer want to reset the timer.
4. Confirm the timer reset by tapping **Yes**. If you don't want to reset the timer, tap **No**.
5. Tap the **Back** button when done to return to the menu. Then **Exit** again to return to the **Home Screen**.

4.13.2 Managing condensation

The myAirvo 3 must be placed below head-height and level. This helps condensate drain into the water chamber and away from the user.

Direct cold air away from the AirSpiral Tube where possible. Air-conditioners, fans, open windows and other sources of cold air may increase condensation.

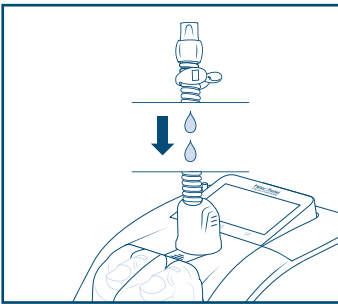
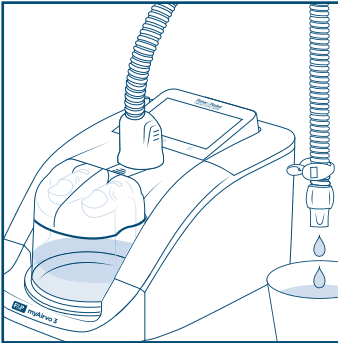
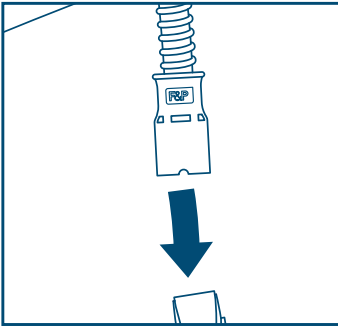

Drain excess condensate that forms in the AirSpiral Tube by:

1. disconnecting the breathing tube from the patient interface, and
2. draining the condensate from the AirSpiral Tube by either:

- Lowering the patient-interface end of the tube into a container. Place the container below the myAirvo 3 so that condensate runs into the container.

Or

- Lifting the patient interface end of the AirSpiral Tube so the condensate runs into the water chamber. If the condensate does not run freely into the water chamber, reduce the flow rate to 30 L/min or less, to allow the condensate to drain (refer to *Adjusting the flow rate* section). Return the flow rate to the prescribed setting after draining the AirSpiral Tube.

Refer to the *Using Condensation Control* section for more information about the **Condensation Control** feature. If condensation persists, talk to your healthcare provider.

4.13.3 Battery operation

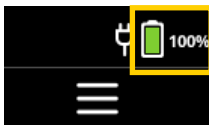

A battery may be fitted to your myAirvo 3 to prevent interruptions to your therapy during power outage. A battery symbol will be displayed in the Message bar if a battery is fitted.

When using myAirvo 3 with the optional battery, you will need to plug in the device in order to successfully start up the device.

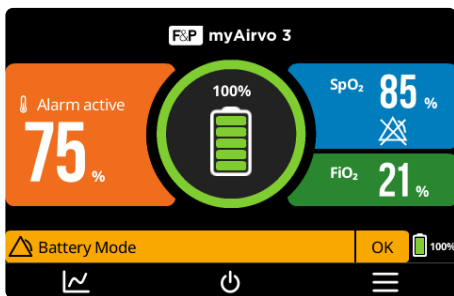

The myAirvo 3 will immediately switch to the internal battery if power is lost so your therapy can continue without interruption. A **Battery Mode** or **Battery Mode: Reduced Humidity** warning will be displayed in the Message bar to let you know that the power source has changed. Reduced humidity will be delivered when the myAirvo 3 is being powered only by the internal battery.

A new battery will provide therapy for approximately 50 minutes when fully charged.

A **Low Battery** alarm will be displayed at less than 35% charge. A **Critically Low Battery** alarm will be displayed at less than 20% charge.

Connect the myAirvo 3 to wall power as soon as possible to continue therapy. The myAirvo 3 will automatically begin charging the battery when it is connected to the wall power.

The signal light will flash green while the battery is charging and will change to a solid green light when fully charged. While the battery is charging, the device will also show an animation of a battery filling up.

If there is an interruption to the power supply and no battery is present or the battery is depleted, the myAirvo 3 will raise a **Power Out** alarm, and if power is not restored, it will turn off and not deliver any therapy to the patient. Once power is restored, the myAirvo 3 can be restarted and will retain the previous therapy and alarm settings.

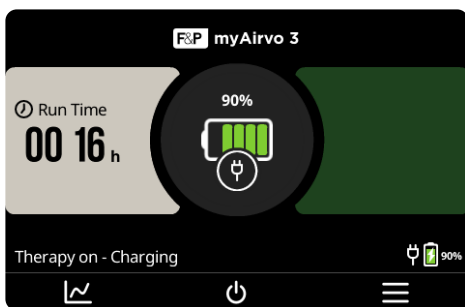
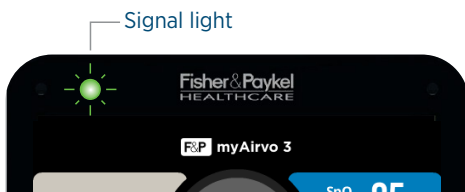

Warnings

- Only charge the myAirvo 3 battery with the myAirvo 3 device.
- Only use the myAirvo 3 battery with the myAirvo 3 device.
- Keep the water chamber level when moving the myAirvo 3. Water can spill inside, and damage the myAirvo 3, if you tilt the device while the chamber contains water.
- Loss of power will result in loss of therapy. In the event of a critically low battery alarm, promptly connect the myAirvo 3 to the wall power supply to avoid loss of therapy due to the battery becoming depleted.
- If using the battery as the power source, periodically check the battery status to ensure the battery does not deplete while therapy is being delivered.
- Contact your healthcare provider to remove the battery from the device if it is not likely to be used for an extended period of time.

Note

If the myAirvo 3 raises a critically low battery alarm, it means the battery level is very low and the device needs to be plugged back into a mains power supply immediately to maintain therapy. Humidification is turned off to maintain operation of the blower and oxygen supply.

4.13.4 Checking battery functionality

Battery functionality can be checked when the myAirvo 3 has finished warming up, before starting therapy.

1. Check that the battery is charged by confirming the battery indicators on the myAirvo 3 shows at least 3 bars.
2. Disconnect the myAirvo 3 power plug from the wall power.
3. Check that you hear an audible alarm and that one of the following alarms is displayed within 10 seconds of the wall power supply being disconnected:
 - Battery mode: Reduced Humidity
 - Low Battery
 - Critically Low Battery
4. Confirm that the myAirvo 3 continues delivering breathing gases by checking for air flowing out of the nasal interface.
5. Connect the myAirvo 3 to the wall supply.

Warning

- Do not use the myAirvo 3 in battery operation if this test fails. Contact your healthcare provider.
- Do not carry out this test when the myAirvo 3 is being used to deliver therapy to a patient.

4.14 Stopping therapy

The myAirvo 3 shows the amount of time that therapy has been delivered in the therapy session on the **Home Screen**. Your healthcare provider will tell you how long to use the myAirvo 3 during each therapy session.

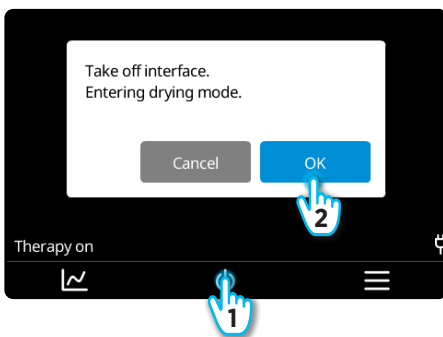

When your session is finished:

1. take off your patient interface,
2. turn off and disconnect any oxygen source attached to the myAirvo 3,
3. hold down the power button (⏻) for 3 seconds to stop therapy and start Drying Mode, then
4. Tap **OK** to confirm that you want to stop therapy and start Drying Mode.

Continue with the next chapter for more information about Drying Mode and the other steps you need to take after each therapy session to keep your myAirvo 3 working properly.

Warning

Do not wear the interface during Drying Mode. The air is hot and dry and may cause injury.

5. After use: caring for your myAirvo 3

It is important to carefully follow these instructions to extend the life of the consumables and prevent damage to the myAirvo 3.

Warnings

The instructions provided here are for a single patient using the myAirvo 3, patient interface, breathing tube and water chamber in their home only.

The patient interface, heated breathing tube, water chamber and outlet elbow may become contaminated during use. If the myAirvo 3 is used by multiple patients (for example, in a long-term care facility):

- The myAirvo 3 and outlet elbow must be cleaned and disinfected between patients. Refer to the disinfection kit (900PT620) manual for the correct procedure.
- The patient interface, heated breathing tube and water chamber must be changed between patients.
- Dispose of all single-use accessories in accordance with local laws and regulations.

5.1 Drying Mode

Daily care begins with an automatic Drying Mode, which dries the AirSpiral Tube and patient interface.

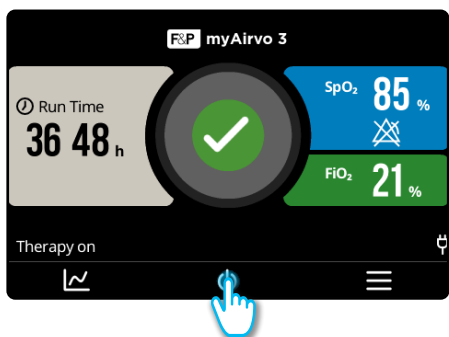

Start Drying Mode when your therapy session is finished by:

1. taking off your patient interface,
2. turning off and disconnecting any oxygen source attached to the myAirvo 3,
3. holding down the power button (⏻) for 3 seconds to stop therapy and start Drying Mode, then

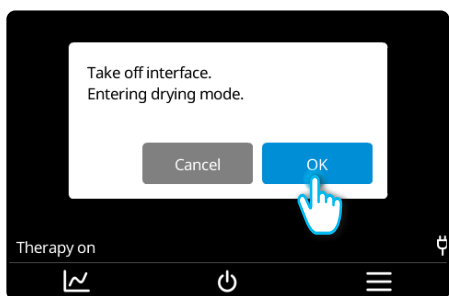

4. tap **OK** to confirm that you want to stop therapy and start Drying Mode.

Drying Mode takes 99 minutes; the countdown shows the time remaining. The myAirvo 3 turns off automatically when Drying Mode is finished.

Leave your myAirvo 3 connected to the wall power while Drying Mode is running. If the wall power supply is turned off or disconnected and the optional battery is depleted or not installed, Drying Mode will stop.



If you need to turn off the myAirvo 3 before Drying Mode has finished, hold down the power button for 3 seconds. However, we recommend that you always allow Drying Mode to finish to help prolong the life of your myAirvo 3.

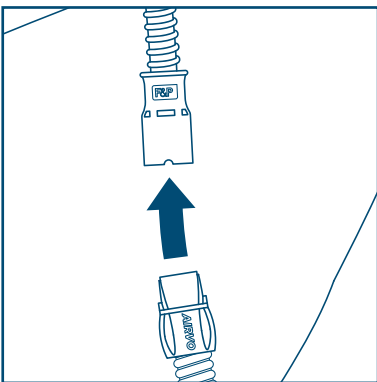
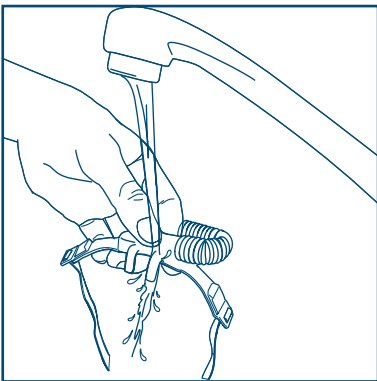
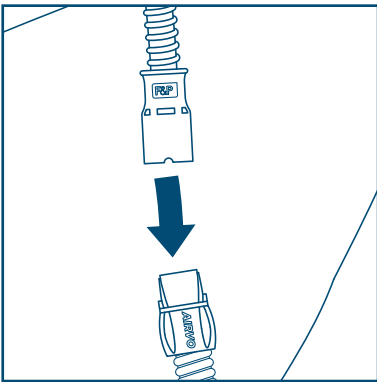
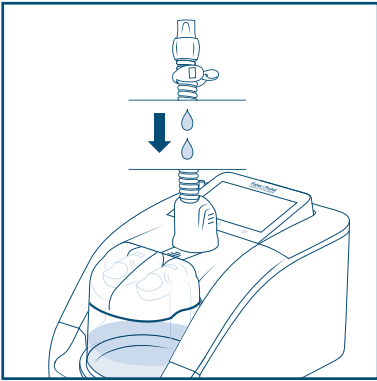

5.2 Daily care

Follow these steps, immediately after stopping therapy, every time that you use the myAirvo 3. Carry out these steps while Drying Mode is running.

1. Drain any excess water from the AirSpiral Tube by lifting the end attached to the patient interface so the water runs into the water chamber.

2. Disconnect the patient interface from the heated breathing tube.

Leave the heated AirSpiral Tube connected and the water chamber installed in the myAirvo 3.

You do not need to empty the water chamber during Drying Mode.

3. If using an Optiflow+ interface, rinse your patient interface in drinkable quality water.

If using the Optiflow Junior 2 Nasal Cannula, do not rinse or wash. Do not soak or sterilize this product. Avoid contact with chemicals, cleaning agents, or hand sanitizers. Secretions on the cannula and the prongs can be removed by gently wiping with a damp cloth.

4. Reconnect the patient interface to the AirSpiral Tube while the myAirvo 3 is still in Drying Mode.

5. If using the Reusable Chamber (MYAIRVOCHAMBER1), check the user manual that accompanies your water chamber and follow the daily care instructions.

6. Follow the weekly care instructions below once a week.

5.3 Weekly care

Follow these instructions each week to care for your myAirvo 3.

You will need:

1. a sink or bowl of warm water and mild dishwashing detergent,
2. a clean, lint-free cloth,
3. drinkable quality water for rinsing, and
4. any additional materials specified in other user manuals.

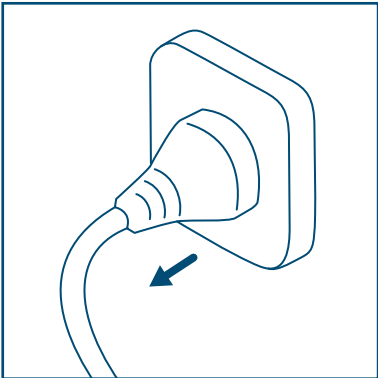

1. Wait until Drying Mode has finished and the myAirvo 3 has turned off.

Unplug your myAirvo 3 from the power socket.

Caution

Electrical shock and flammability hazard: Before cleaning, always turn off the device and disconnect from any power source.

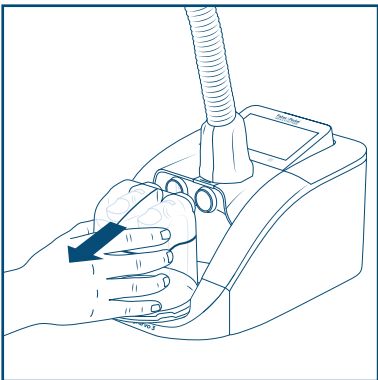

2. Remove the water chamber and AirSpiral Tube from your myAirvo 3. Detach your patient interface from the AirSpiral Tube.

Remove the water chamber by gripping the sides of the chamber while pressing down the fingerguard, and sliding it back out of your myAirvo 3.

If using the Auto-fill chamber with the water bag, carefully put them aside.

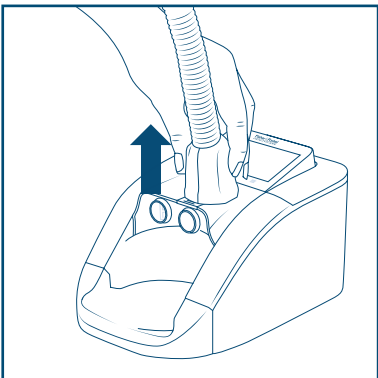

3. Detach the AirSpiral Tube from your myAirvo 3 by squeezing the sides of the AirSpiral Tube connector and pulling up. Drain any excess water from the AirSpiral Tube.

Warning

Turn off the myAirvo 3 and disconnect the device from the wall power supply before disconnecting the breathing tube and water chamber to reduce the risk of electric shock.

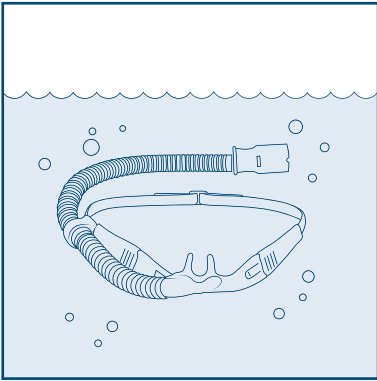

4. If using an Optiflow+ interface, wash your patient interface in the bowl of warm water and mild detergent.

Rinse the interface in drinkable quality water.

If using the Optiflow Junior 2 Nasal Cannula, discard every two weeks as per user manual.

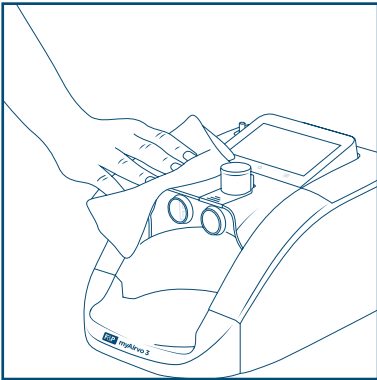

5. Dip a lint-free cloth in the warm water and mild detergent, wring it out so the cloth is damp but not wet. Then thoroughly wipe the outside of the myAirvo 3.

Warning

Do not use harsh abrasives or solvents on the myAirvo 3, or any accessories. They may cause permanent damage.

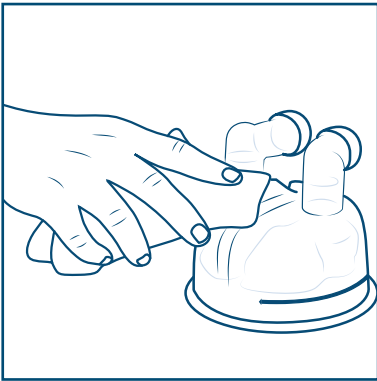

6. If using the Auto-fill Chamber (MYAIRVOKIT1 or 900PT290E) with the Water Bag, wipe the outside of the water chamber using the damp lint-free cloth. Do not wash this chamber.

If using the Reusable Chamber (MYAIRVOCHAMBER1), check the user manual that accompanies your water chamber and follow the weekly care instructions.

7. Reassemble your myAirvo 3 so that it is ready for your next therapy session. Follow the steps starting on page 11 to set up your myAirvo 3.

5.4 Timetable for changing accessories

The patient interface, AirSpiral Tube, water chamber and Water Bag must be changed regularly to avoid the risk of infection. Replace each accessory within the period shown below, or immediately if they are damaged or discolored.

Dispose of used patient interfaces, AirSpiral Tube, Water Bag (if applicable), and chambers in a waste bag and discard with normal household waste and/or according to local guidelines.

Description	Maximum Use	Part Number
Optiflow Junior 2 patient interfaces	14 days, 1 patient	5-pack OJR416HM, OJR418HM
Optiflow+ patient interfaces	30 days, 1 patient	2-pack MYOPT9SMALL, MYOPT9MEDIUM, MYOPT9LARGE, MYOPT9TRACHE, MYOPT9MASK
		1-pack OPT942E, OPT944E, OPT946E, OPT970E, OPT980E
		2-pack MYDUETSMALL, MYDUETMEDIUM, MYDUETLARGE
All breathing tubes and Auto-fill Chamber	60 days, 1 patient	MYAIRVOKIT1, MYAIRSPIRAL, 900PT560E, 900PT560
Reusable water chamber	2 years, 1 patient	MYAIRVOCHAMBER1
Water Bag	60 days (or sooner if significantly discolored)	900PT401
Air filter	3 months or 1000 hours use (or if significantly discolored)	900PT933
Optional battery	300 cycles or 2 years from date of manufacturer (whichever comes first)	900PT957L
Pulse oximetry USB connector, adapter and sensor cables	Refer to instructions for use supplied with device.	Refer to part number list in section 12.3

Some products may not be available in your country. Please contact your healthcare provider or Fisher & Paykel Healthcare representative.

Warnings

- All the patient interfaces, water chambers and breathing tubes shown in the table above are for single patient use only.
- Use only compatible accessories with the myAirvo 3.

5.5 Air filter replacement

The air filter should be replaced after 3 months, 1000 hours use or when significantly discolored - whichever comes first.

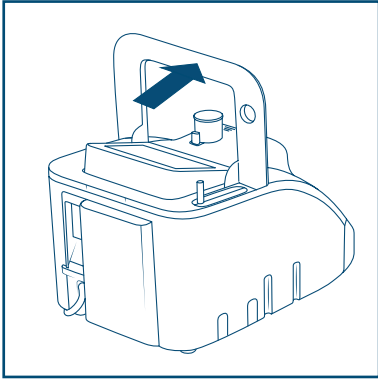

Begin by removing the old filter:

1. Raise the filter cover.

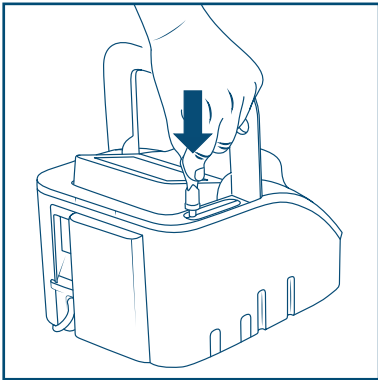

2. Push the filter grip firmly onto the low-pressure oxygen inlet port.

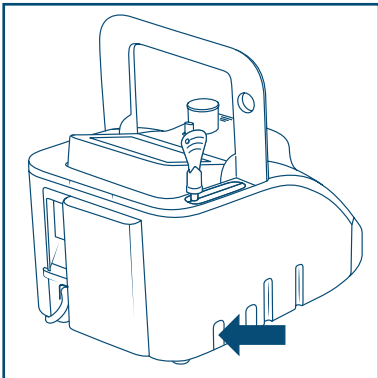

3. Hold down the air-filter release button.

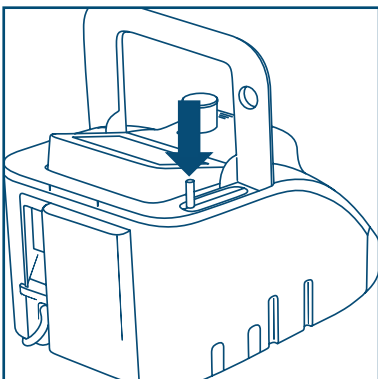

4. Pull up on the filter grip.
5. Insert the new filter, pushing down on the top of the filter until it clicks into place. Then lower the filter cover.

5.6 Servicing

The myAirvo 3 does not require regular maintenance and contains no routine servicing. Refer to the myAirvo 3 Technical Guide for product acceptance checks, functional tests and replacement parts.

If a battery is fitted, the myAirvo 3 will display a **Replace Battery** notification on start-up when it is time to replace the battery. Return the device to your healthcare provider for servicing when the **Replace Battery** alarm is displayed. You may keep using your myAirvo 3 until the battery is replaced however the device may shut down immediately when it is unplugged from the wall power.

Contact your healthcare provider if a fault develops or you are concerned the myAirvo 3 is not operating properly.

Warning

Do not service or maintain the myAirvo 3 while it is being used by a patient.

5.7 Software update

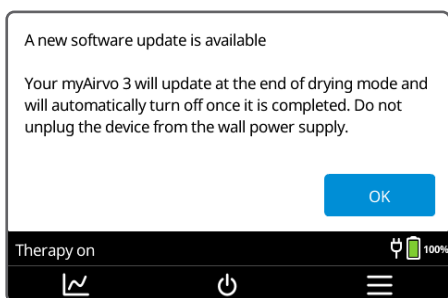

When a software update is available, the myAirvo 3 will automatically install it at the end of drying mode.

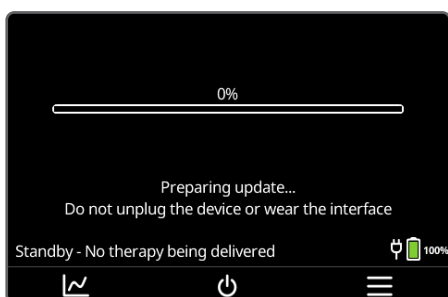

5.8 Storage

Store the myAirvo 3 in a clean, dry and dust-free environment between use. To maintain the battery and prolong its life, fully recharge the battery monthly during long-term storage.

6. Sharing your therapy data

The information collected by your myAirvo 3 can be used by your healthcare provider to help manage your therapy. Therapy data can be sent from your myAirvo 3 using either a:

1. built-in cellular modem
2. myAirvo 3 InfoUSB.

Data exchange is protected using industry-standard encryption to protect your privacy. Only your healthcare provider has access to your patient data.

6.1 Your personal data

Your myAirvo 3 is not designed to collect identifiable information about you. To function effectively, the myAirvo 3 will collect and store limited therapy data when you use it to deliver intended therapies. Your data will be securely stored on your myAirvo 3 unless you choose to share your therapy data with your healthcare provider. If you choose to share your therapy data, your data may become identifiable using your device identifier combined with your other health records. You can ask your healthcare provider if they intend to collect your therapy data, and how that impacts your privacy, as part of their healthcare services to you. Data is retained on your device until you choose to delete it or until maximum data is stored and automatically deleted. Refer to the Product Technical Guide for more detail on how long categories of data may be stored.

Limited myAirvo 3 device information may be collected and shared with F&P Healthcare regarding device performance, including device identifiers. This is to monitor ongoing medical device effectiveness and improvement opportunities, e.g. firmware. Information is stored and used securely by F&P Healthcare, separate from other product data F&P Healthcare may process. For more information about your data using myAirvo 3, see the Product Technical Guide. For more about how F&P Healthcare manages personal information, including your privacy rights to request access, correct or delete your information, please see our Global Privacy Statement on our website.

If you choose to support F&P Healthcare in developing and improving our products and services, or to receive personalized services, you may be asked to complete additional questionnaires about your profile, clinical diagnosis, and other information. We will also collect information about your locality (at the city level), but we will not know your exact address.

If you choose to share your data with F&P Healthcare, we will protect it and use it to better support patients like you. Your data will be securely stored and kept confidential, and it will not be shared externally without your permission. You will have the option to change your preferences at any time. For more information, please consult the Privacy Notice in the consent preferences tab of your myAirvo 3 device.

6.2 Cellular modem

If your myAirvo 3 includes a wireless modem and it is enabled, it will automatically upload your therapy data to your healthcare provider. The connection to your healthcare provider is made automatically using the cellular network.

Note

- By default the cellular modem is enabled. To disable the cellular modem, follow the instructions in section 6.2.2.

6.2.1 Data transfer

The myAirvo 3 may send the following information, using a secure communication protocol, to your healthcare provider:

- Therapy settings, e.g. target flow, etc.
- Physiological data (if applicable), e.g. SpO₂, etc.
- Responses to diary card questions (if diary cards are enabled).

6.2.2 Modem settings

Your cellular modem should remain on so that the myAirvo 3 can be uploaded to your healthcare provider. To disable your modem:

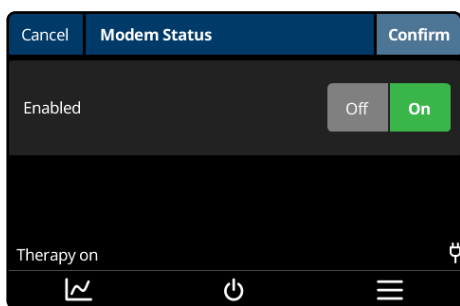

1. Select **Device info** then **Modem status** from the myAirvo menu to open the modem settings page
2. Select **Off** to turn the modem off to prevent data uploads. Otherwise, select **On** to turn the modem on so that myAirvo 3 can upload data to your healthcare provider.
3. Tap **Confirm** to apply changes or **Cancel** to discard any changes.

6.3 Loading data onto the myAirvo 3 InfoUSB

The myAirvo 3 InfoUSB automatically retrieves your therapy data when it is plugged into one of the USB ports on the back of your myAirvo 3. Your healthcare provider will provide you with an myAirvo 3 InfoUSB and tell you how they would like to transfer the data. You may need to:

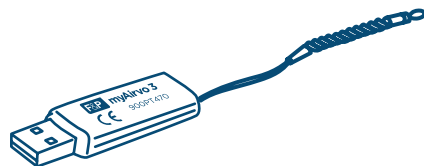

- use your home computer, or
- take the myAirvo 3 InfoUSB to your healthcare provider.

Note

- Do not remove myAirvo 3 InfoUSB from the myAirvo 3 during data transfer.
- Use a computer with up-to-date antivirus software installed.
- Do not plug myAirvo 3 InfoUSB into any unsupported devices.
- Plugging incompatible USB flash drives into the myAirvo 3 USB port may cause data corruption, damage to the myAirvo 3 or the USB flash drive.
- Use the myAirvo 3 InfoUSB only with the InfoUSB application. Altering data on the myAirvo 3 InfoUSB with other programs may cause data corruption or damage the myAirvo 3.
- Do not store personal files on the myAirvo 3 InfoUSB.
- Do not reformat the myAirvo 3 InfoUSB.

Warning

To avoid choking, please keep the myAirvo 3 InfoUSB away from children.

6.3.1 Loading data onto the myAirvo 3 InfoUSB

The myAirvo 3 InfoUSB has been designed to plug into your myAirvo 3 where data is periodically synchronized from the myAirvo 3 to the myAirvo 3 InfoUSB.

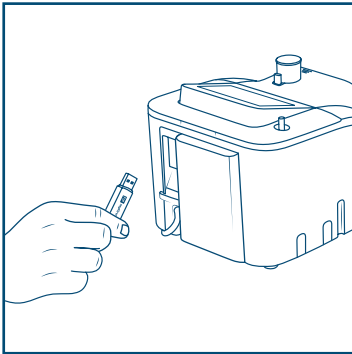

To use your myAirvo 3 InfoUSB:

1. Plug the myAirvo 3 InfoUSB into one of the ports on the back of your myAirvo 3.
2. Check that the myAirvo 3 InfoUSB has been detected by confirming the  icon is displayed.

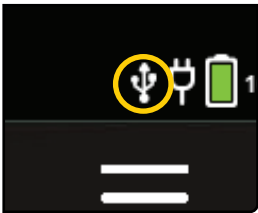

3. The  icon will flash while data is being transferred. Do not remove the myAirvo 3 InfoUSB from the myAirvo 3 until the transfer is complete. The transfer may take up to 30 minutes.
4. Remove the myAirvo 3 InfoUSB from the myAirvo 3 when you are ready to upload data or when requested by your healthcare provider.

6.3.2 Uploading with the F&P InfoUSB application

The F&P InfoUSB application lets you send myAirvo 3 therapy data to your healthcare provider. You will need a Microsoft Windows computer running Windows 7 or later. You will also need a spare USB port for the myAirvo 3 InfoUSB and an Internet connection.

Installing the InfoUSB application and transferring data

1. Insert into computer

When requested by your healthcare provider, remove the InfoUSB from your myAirvo 3 device and insert it into the USB port of a computer.

2. Install F&P InfoUSB on your Microsoft Windows computer:

Click on the **Start** button and open **This PC**. Navigate to the drive called **FPHCARE**. Open this folder and double-click on the **Setup** file. Follow the on-screen instructions. Upon successful installation of the InfoUSB application, the message in Step 3 will appear.

3. Data Transfer

Upon detection of an myAirvo 3 InfoUSB in your computer, a prompt will automatically appear. Enter your Date of Birth and select the Upload button. Ensure that your computer is connected to the Internet for successful data transfer to your healthcare provider.

4. Confirmation

After the data has been sent successfully, a confirmation message will appear. Remove the InfoUSB from your computer and place it back into your myAirvo 3 device. Your myAirvo 3 is now ready to be used for continued therapy.

Future Logging

The next time you need to transfer your data to your healthcare provider, simply insert the myAirvo 3 InfoUSB into your computer and the message in Step 3 will automatically appear.

7. Viewing your therapy data

The myAirvo 3 records the amount of time it has been used. Tap the Usage information button to view:

The vertical daily usage bar will change colour based on your activity:

Blue - daily usage goal reached

Red - daily usage goal not reached

Green - current daily usage

Red horizontal line

If enabled by your healthcare provider, this indicates your daily usage goal

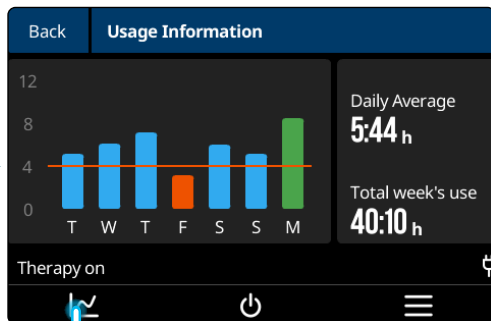

The daily average number of hours that your myAirvo 3 has been used over the previous 7 days, not including the current day.

Total time your myAirvo 3 has been used for the past 7 days, including today.

Usage information

8. Traveling with myAirvo 3

The myAirvo 3 can be used in any country with a 110 – 240VAC wall power supply, with an appropriate travel adapter.

Refer to the Timetable for changing accessories on page 32 to make sure you have the accessories you'll need for the duration of your trip.

The myAirvo 3 is not certified for use on an aircraft. Ask your airline if you can take the myAirvo 3 with you as carry-on luggage when travelling by airplane.

Warning

Empty the water chamber before packing or transporting the myAirvo 3 to prevent water damage to the device, accessories or your luggage.

9. Alarms

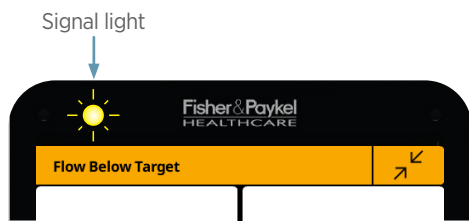

The myAirvo 3 has visual and audible alarms to warn you about conditions that affect your therapy. All alarms require your attention.

The signal light flashes when any alarm is active. Its color indicates the highest priority alarm that is active.

9.1 Alarm priority

Alarms are grouped by urgency and severity into three priority levels: low, medium, high. When multiple alarms are active, the audible alert, signal light, and message bar background color will signal the highest priority alarm.

Alarm priorities have been allocated for an operator's position within 2 meters (6.5ft) of the device. The unit also uses an internal-priority ranking system. If multiple alarm conditions occur simultaneously, the unit will display an alarm list screen, displaying the highest-priority alarm for each alarm category. Contact your healthcare provider if any problem persists.

- A response is needed for all alarms.
- A prompt response is required for all medium priority alarms.
- An immediate response is required for all high priority alarms.

Priority	Title bar, message bar, signal light color	Audible alert
Low	Solid yellow	High then low pitch beep
Medium	Flashing yellow	3 beeps every 9 seconds
High	Flashing red	3 beeps then 2 beeps every 5 seconds

Warning

Audible alarms may not be heard if the Sound volume is set lower than ambient noise. Missed alarms may lead to patient injury. Refer to the myAirvo 3 Technical Guide to review and set the alarm volume.

9.2 Audible information signals

The informative sounds made by the myAirvo 3 are:



Melody	Meaning
Ascending sequence of 3 tones	The myAirvo 3 has powered on.
Ascending sequence of 5 tones	The breathing gas has reached the target settings; the myAirvo 3 is ready for use. This melody will also play when unlocking the device.
Single tone	A touch on the display was registered.
Single low then high tone.	All active alarms are resolved.
Descending sequence of 5 tones	Drying Mode has started. This melody will also play when locking the device.
Descending sequence of 3 tones.	The myAirvo 3 has powered off.
Single high then 2 low tones	Power Out alarm

9.3 Viewing alarm details

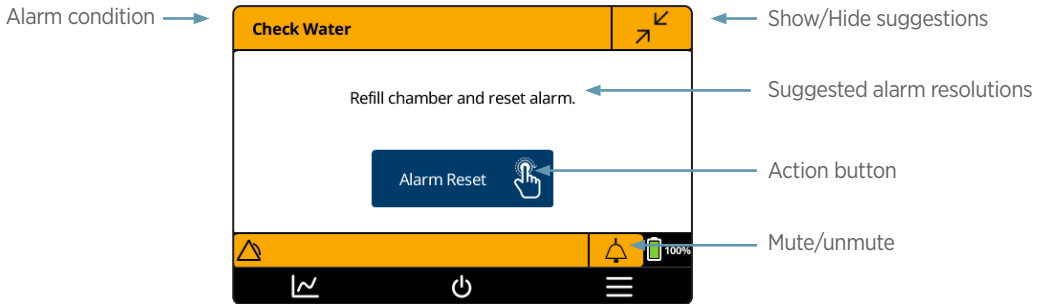
Alarms are displayed with suggested resolutions and action buttons for managing the alarm information:



Tap **Audio Pause** to silence the alarm for 120 seconds. The Audio Pause button will change to  when audible alarms are silenced.

- Use   to page through multiple suggestions. Some alarms have only one suggested resolution.
- Tap **Hide suggestions** to collapse the alarm information to the message bar. Restore suggestions by tapping the alarm condition on the message bar.

The message bar displays the name of active alarms and an action button. When multiple alarms are active the message bar cycles through the active alarms. Tapping the message bar displays a list of active alarms. Alarms are presented in the order that they occurred, with the earliest alarm shown on the top of the stack. The color of the message bar always indicates the highest priority active alarm.

Alarm signals always indicate the highest priority active alarm condition (see Alarm priority above).



9.4 Device alarms

All the alarms you may encounter while using the myAirvo 3 are listed below with common causes, resolutions and any delays inherent in determining alarm conditions. These priorities have been allocated for an intended operator's position of 2 meters (6.5 ft) from the device. The myAirvo 3 also uses an internal-priority ranking system. If multiple alarm conditions occur simultaneously, the device will display the highest-priority alarm for each alarm category.

Alarm Condition	Priority	Delay	Meaning
Faults			
Device Fault [Error Code]	High	-	A technical fault has occurred that has caused therapy to be stopped. Restart the device to resolve the fault. If the issue persists, contact your service representative.
Device Fault [Error Code]	Med.	-	A technical fault has occurred, and the device is able to continue supplying limited therapy. Restart the device to resolve the fault. If the issue persists, contact your service representative.
Power alarms			
Power Out	High	≤ 5 s	The myAirvo 3 has been disconnected from the wall power supply and the internal battery (if equipped) is depleted. The auditory alarm will sound once every 10 seconds for 120 seconds and the signal light above the touch screen will flash. The touch screen is off during the Power Out alarm. The myAirvo 3 will shut down after signaling the Power Out alarm but will restart automatically if power is restored before it shuts down.
Unsupported Battery	Med.	≤ 5 s	The device is running off the battery and either an incorrect battery type is connected or communication with the battery could not be established.
Critically Low Battery	Med.	≤ 5 s	The myAirvo 3 battery level is critically low. Connect the myAirvo 3 to the wall power supply immediately to maintain therapy. Humidification is turned off to maintain operation of the blower and oxygen supply.
Low Battery	Low	≤ 5 s	The myAirvo 3 battery level is low and should be connected to the wall power supply. Therapy continues as normal.
Battery Not Functional	Low	≤ 5 s	The myAirvo 3 has detected a battery failure. Replace the battery.
Battery Mode: Reduced Humidity	Low	≤ 5 s	The myAirvo 3 has been disconnected from the wall power supply and the device is now running off the battery. The delivered humidity may be reduced.
Battery Charger Fault	Low	≤ 30 s	The battery charger is not functioning correctly and has been disabled. Restart the device to resolve the fault. If the issue persists, contact your service representative.
Therapy alarm - tube			
Outlet Elbow Missing	High	≤ 15 s	The myAirvo 3 outlet elbow has been removed from the device during therapy. Check that the outlet elbow is fully inserted into the myAirvo 3. If the issue persists, replace the outlet elbow.
Check Tube	Med.	≤ 5 s	The myAirvo 3 cannot detect the AirSpiral Tube. Check that the AirSpiral Tube is connected correctly. Replace the AirSpiral Tube if the problem persists.
Wrong Tube	Med.	≤ 5 s	The AirSpiral Tube is not suitable for the selected therapy. Connect a suitable AirSpiral Tube. Replace the AirSpiral Tube if the problem persists.
Outlet Elbow Fault	Med.	≤ 5 s	A fault has been detected with the outlet elbow. Check that the outlet elbow is fully inserted into the myAirvo 3. If the issue persists, replace the outlet elbow.
Outlet Elbow Too Warm	Med.	≤ 5 s	The outlet elbow is too warm to run start up checks. Wait for the outlet elbow to cool down. If the issue persists, replace the outlet elbow.

Therapy alarm - high flow			
Chamber Leak Detected	Med.	≤ 30 s	The water chamber has been removed. Ensure the water chamber is correctly inserted into the myAirvo 3. If the issue persists, contact your service representative.
Leak Detected	Med.	≤ 30 s	The myAirvo 3 has detected a leak in the breathing circuit. Check: <ul style="list-style-type: none"> the water chamber has not been removed and is properly installed, the AirSpiral Tube is plugged in correctly, and the patient interface is fitted correctly.
Blockage Detected	Med.	≤15 s*	The myAirvo 3 has detected a blockage. Check: <ul style="list-style-type: none"> for blockages in the AirSpiral Tube, patient interface and inlet air filter the patient interface is the correct size for the patient, and the target flow rate is within the rated range of the interface. If the issue persists, replace the consumables.
Flow Below Target	Med.	≤ 2 min	The myAirvo 3 cannot reach the target flow rate. Check: <ul style="list-style-type: none"> for blockages in the AirSpiral Tube, patient interface and inlet air filter, the patient interface is the correct size for the patient, and the target flow rate is within the rated range of the interface. If the issue persists, replace the consumables.
Flow Above Target	Low	≤ 2 min	The myAirvo 3 flow rate is higher than the target flow rate. Check: <ul style="list-style-type: none"> for leaks in the water chamber, heated breathing tube and patient interface, the inlet air filter is inserted correctly, and the target flow rate is within the rated range of the interface If the issue persists, replace the consumables.
Therapy alarm - other			
Target Flow Too High	Med.	≤ 60 s*	The myAirvo 3 has exceeded an internal temperature limit. Continued operation at the current settings may result in a device fault and reduced therapy. Check the target flow rate is within the rated range of the interface, and adjust settings if appropriate. This alarm will resolve when the internal temperature is within the expected range.
Check Water	Med.	≤ 30 min	The water chamber has run out of water. Replace the water chamber and water bag to resume normal operation. Ensure that the water chamber and/or water bag are not allowed to run out of water to ensure continuous humidification of the breathing gases.
Humidity Below Target	Med.	≤ 30 min*	The myAirvo 3 cannot reach the target humidity. Check the water chamber contains water. Consider reducing the target humidity or flow rate, if appropriate. If the issue persists, replace the water chamber.
Check Operating Conditions	Low	≤ 1 min*	The myAirvo 3 has detected ambient conditions that are not suitable. Do not use the myAirvo 3 when the ambient temperature is below 18 °C or above 28 °C (below 64 °F, above 82 °F). Move the device to a suitable environment.
Oxygen alarms			
Low Oxygen	Med.	≤ 30 s*	The FiO ₂ is below 25%. Check: <ul style="list-style-type: none"> the oxygen supply is properly connected, and the oxygen supply is not empty or turned off Note: A grace period of 6 minutes is provided at the start of therapy before this alarm will activate.
Unexpected O₂	Med.	≤ 2 min*	Oxygen is being supplied to the myAirvo 3 while in Drying Mode.
High FiO₂	Med.	≤ 20 s	The measured oxygen fraction is above the limit set by the healthcare provider (refer to the myAirvo 3 Product Technical Guide for settings). Reduce the FiO ₂ to a normal range when it is appropriate to do so.

*An additional alarm signal generation delay of 2 s applies.

9.5 Checking the alarm system

The alarm system functionality can be checked whenever the myAirvo 3 is turned on.

Check the alarm system is functioning correctly by disconnecting the AirSpiral Tube from the myAirvo 3.

You should:

1. See the “Tube Missing” visual alarm on the myAirvo 3 screen, and
2. See the Signal light flash yellow, and
3. Hear the myAirvo 3 internal audible alarm.

Warning

Do not use the myAirvo 3 if either visual alarm or the audible alarm is absent. Instead, contact your healthcare provider.

10. Pulse oximetry

The myAirvo 3 can monitor and record your peripheral blood-oxygen saturation (SpO₂) and pulse rate using a pulse oximeter to help your healthcare provider evaluate and adjust your therapy. No SpO₂ or pulse rate alarms are included in the myAirvo 3.

Not all patients require pulse oximetry measurements. Your healthcare provider will provide the equipment needed if your physician has prescribed pulse oximetry.

The myAirvo 3 supports the following pulse oximeter accessories:

- The Nonin Xpod 3012LP USB (6703-001)

Pulse oximeters primarily measure the oxygen saturation of blood and pulse rate. Oxygen saturation or SpO₂ is the percentage of hemoglobin in the blood that is saturated with oxygen. Hemoglobin is a protein in the red blood cells that carries oxygen from the lungs to the rest of the body. Pulse rate is the number of heart beats per minute.

A pulse oximeter operates by emitting two different wavelengths of light, typically red and infrared, into a perfused tissue site such as a fingertip or earlobe. The emitted light passes through the tissue, and a photodetector in the sensor measures the intensity of the transmitted or reflected light. By comparing the absorption of red and infrared light, the pulse oximeter calculates the ratio of oxygenated to total hemoglobin in the blood, which is used to determine the oxygen saturation level. Additionally, the device analyzes the variations in the light intensity to measure the patient's pulse rate.

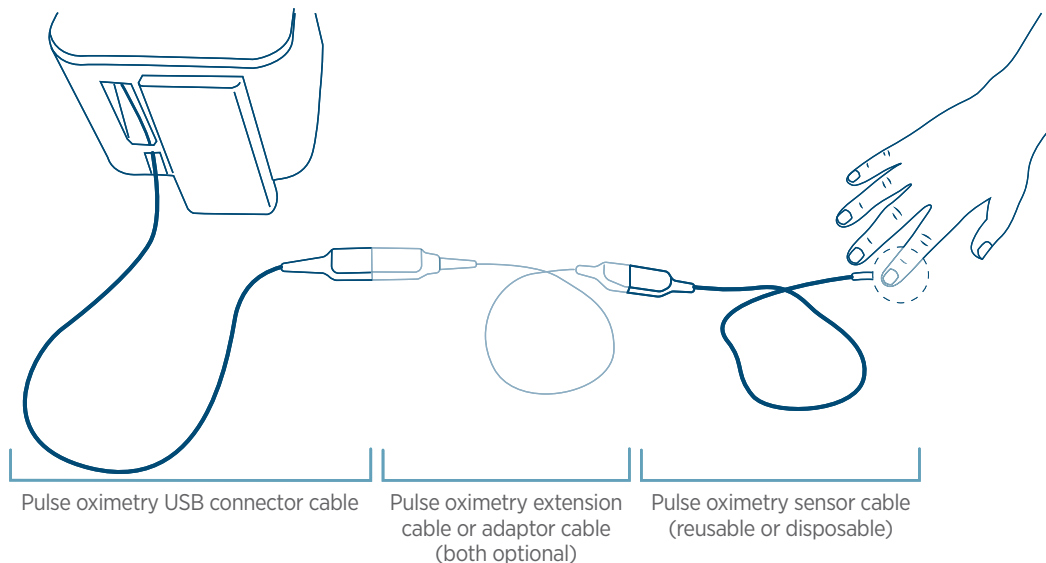

Warnings

- Periodically reposition the sensor to help prevent ischemia.
- If any measurement seems questionable, first check the patient's vital signs by alternate means and then check the pulse oximeter for proper functioning.
- Carefully route cabling to reduce the possibility of patient entanglement or strangulation.
- Use only compatible oximetry sensors and accessories for SpO₂ and pulse rate measurements. Verify compatibility before use to avoid incorrect operation of your myAirvo 3, inaccurate measurements and/or patient injury.

- Do not use single-patient use pulse oximeter sensors on more than one patient to avoid cross-infection and/or contamination.
- Refer to the third party pulse oximeter sensor instructions for use for information on the risks of re-using a single use sensor.
- Follow the user instructions supplied with multi-use pulse oximeter sensors, adaptors and USB connector cables to clean and disinfect these devices between patients to avoid cross-infection and/or contamination.
- Use only compatible oximetry sensors and accessories for SpO₂ and pulse rate measurements. Verify compatibility before use to avoid incorrect operation of your myAirvo 3, inaccurate measurements and/or patient injury.

Nonin:

- Using any sensors other than Nonin-branded PureLight® sensors with the Nonin Xpod USB connector may result in inaccurate performance (of the myAirvo 3 and/or Nonin products) and will void the Nonin product warranty.
- Do not use the pulse oximeter sensor, cable or adapter if it appears, or is suspected to be, damaged.
- Operation of the Nonin Xpod USB connector below the minimum amplitude of 0.3% modulation may cause inaccurate results.

Cautions

- Before cleaning the pulse oximetry accessories, disconnect the device from the myAirvo 3 to avoid electrical shock and flammability hazards.
- Do not place the pulse oximetry accessories on electrical equipment that may affect the device, preventing it from working properly.
- To minimize radio interference, other electrical equipment that emits radio frequency transmissions should not be in close proximity to the pulse oximeter equipment.
- If using pulse oximetry during full body irradiation, keep the sensor out of the radiation field. If the sensor is exposed to the radiation, the reading might be inaccurate or the device might read zero for the duration of the active irradiation period.
- Variation in measurements may be profound and may be affected by sampling technique as well as the patient's physiological conditions. Any results exhibiting inconsistency with the patient's clinical status should be repeated and/or supplemented with additional test data. Blood samples should be analyzed by laboratory instruments prior to clinical decision making to completely understand the patient's condition.
- The accuracy of the SpO₂ measurement may be affected if the total sensor cable length (including extension cables) is greater than 3 meters (9.8 feet).
- Setting extreme alarm thresholds can render alarms useless and may lead to patient injury.
- Inspect the sensor application site at least every 6 to 8 hours to ensure correct sensor alignment and skin integrity. Patient sensitivity may vary due to medical status or skin condition. Discontinue use of adhesive tape sensors if the patient exhibits an allergic reaction to the adhesive material.

Nonin:

- The Nonin Xpod USB connector has motion tolerant software that minimizes the likelihood of motion artefact being misinterpreted as good pulse quality. In some circumstances, however, this device may still interpret motion as good pulse quality. This covers all available outputs (i.e. SpO₂ , PR, PLETH, PPG).

10.1 Set up the pulse oximeter

Read the instructions supplied with the pulse oximetry accessories for additional safety information (including any potential risks or adverse effects from sensor materials), measurement site selection, detailed sensor setup, maximum sensor application time at a single site before repositioning, cable lifetime, sensor lifetime, factors that can interfere with measurement, troubleshooting and maintenance instructions.

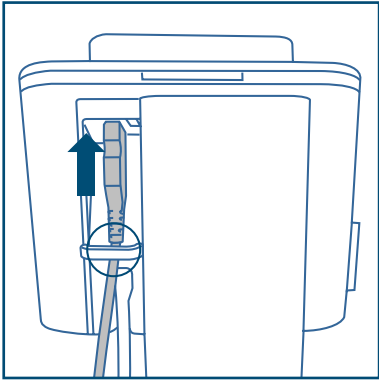

Plug the USB connector cable into either of the USB ports on the back of the myAirvo 3. Clip the pulse oximeter's cable into the cable tidy so that it is not pulled out accidentally. The myAirvo 3 will automatically detect a compatible pulse oximeter.

You can connect the pulse oximeter when the myAirvo 3 is on or off.

Connect the sensor cable to the other end of the USB connector cable.

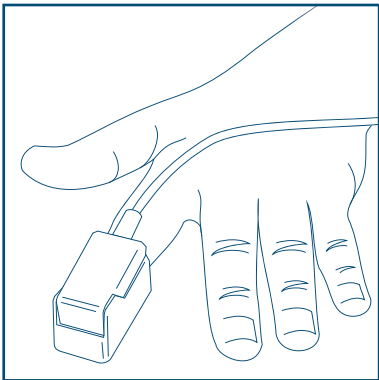

Attach the sensor to the patient.

Carefully select a pulse oximetry sensor based on the patient's age and weight as well as the intended sensor application site.

Generally, choose a site that is well perfused and least restricts movement. The ring finger of the non-dominant hand is preferred for adults.

Bright light sources including direct sunlight, lamps, fluorescent lights and infrared heating lamps can interfere with pulse oximeter measurements. You may need to cover the sensor with an opaque material, such as blanket or cushion to prevent interference.

Warnings

Inaccurate SpO₂ and/or pulse-rate readings may be caused by:

- Improper sensor application and placement.
- Elevated levels of Carboxyhemoglobin (COHb) or methaemoglobin (MetHb): High levels of COHb or MetHb may occur with a seemingly normal SpO₂. When elevated levels of COHb or MetHb are suspected, laboratory analysis (COOximetry) of a blood sample should be performed.
- Elevated levels of bilirubin.
- Elevated levels of dyshemoglobin.
- Vasospastic disease, such as Raynaud's, and peripheral vascular disease.
- Hemoglobinopathies and synthesis disorders such as thalassemia, Hb s, Hb c, and sickle cell, etc.
- Hypocapnic or hypercapnic conditions.
- Severe anemia.
- Very low arterial perfusion .
- Extreme motion artifact.
- Abnormal venous pulsation or constriction.
- Severe vasoconstriction or hypothermia.
- Arterial catheters and intra-aortic balloon.
- Intravascular dyes, such as indocynine green or methylene blue.

- Externally applied coloring and texture, such as nail polish, acrylic nails, glitter, etc.
 - Birthmark(s), tattoos, skin discolorations, moisture on skin, deformed or abnormal fingers etc.
 - Skin color disorders.
 - Excessive ambient light
 - Excessive motion
 - Electrosurgical interference
 - Blood flow restrictors (arterial catheters, blood pressure cuffs, infusion lines, etc.)
 - Moisture in the sensor
 - Improperly applied sensor
 - Incorrect sensor type
 - Poor pulse quality
 - Venous pulsations
 - Low haemoglobin concentrations
 - A sensor not at heart level
- Dyes or any substance containing dyes that change usual blood pigmentation may cause erroneous readings.
 - Loss of monitoring can result if any objects hinder the pulse measurement. Ensure that no blood flow restrictors (e.g., blood pressure cuff) hinder pulse measurements.
 - The oximeter sensor may not work on cold extremities due to reduced circulation. Warm or rub the finger to increase circulation or reposition the sensor.
 - Inaccurate readings can result due to residue (e.g. dried blood) in light path or degradation of optical characteristics of sensor components. Refer to cleaning instructions supplied with the pulse oximetry accessories.
 - False high readings can result if SpO₂ is low due to dysfunctional hemoglobin (e.g. carboxyhemoglobin or methemoglobin).
 - Read the instructions supplied with the pulse oximetry accessories for additional safety information (including any potential risks or adverse effects from sensor materials), measurement site selection, detailed sensor setup, maximum sensor application time at a single site before repositioning, cable lifetime, sensor lifetime, factors that can interfere with measurement, troubleshooting and maintenance instructions.

Cautions

- Inspect the measurement site as directed in the sensor's user manual to ensure skin integrity and correct positioning and adhesion of the sensor.
- A functional tester cannot be used to assess the accuracy of a pulse oximeter or sensor.

Nonin:

- Inspect the sensor application site at least every 6 to 8 hours to ensure correct sensor alignment and skin integrity. Patient sensitivity may vary due to medical status or skin condition. Discontinue use of adhesive tape sensors if the patient exhibits an allergic reaction to the adhesive material.
- The accuracy of the SpO₂ measurement may be affected if the total sensor cable length (including extension cables) is greater than 3 meters (9.8 feet)

10.2 Using the pulse oximeter

If a compatible pulse oximeter is connected to the myAirvo 3, the Home Screen will display a blue pulse oximeter tile.

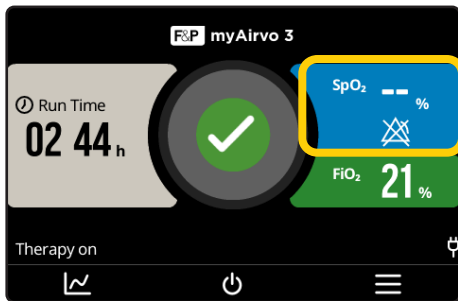

A '--' indicates that the pulse oximeter has been detected and is currently not returning a valid SpO₂ value. Place the sensor on the measurement site and wait for the SpO₂ value to populate.

Depending on the settings your healthcare provider has selected, you may or may not see the SpO₂ value.

If SpO₂ value is displayed:

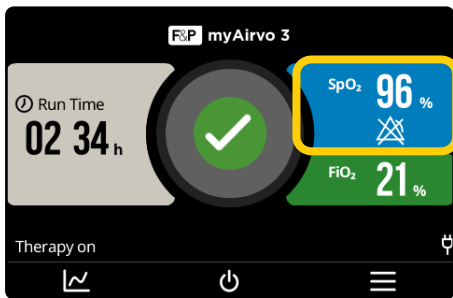

SpO₂ signal is strong and reading correctly.

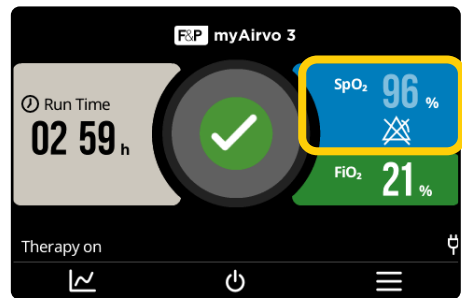

SpO₂ signal quality is low.*

If SpO₂ value is not displayed:

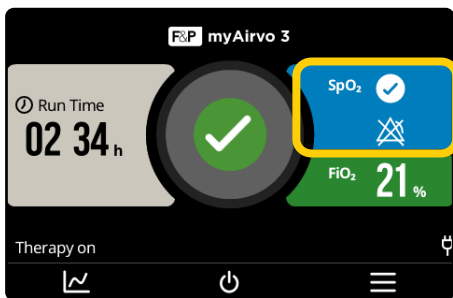

SpO₂ signal is strong and reading correctly.

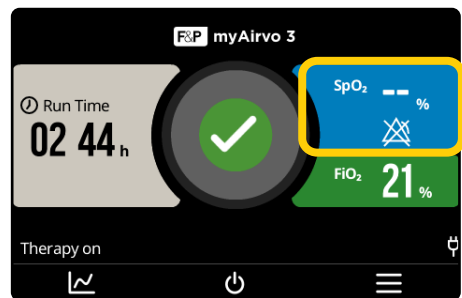

There is no SpO₂ signal available.*

* Check that the sensor is properly attached to the patient and avoid a lot of movement. Try moving the sensor to a new location if the problem continues.

SpO₂ monitoring will restart automatically whenever a reliable signal is detected, including after power is restored following interruption to the power supply.

Warning

Follow the pulse oximeter sensor user manual to periodically reposition the sensor to help prevent ischemia.

10.3 After use

Remove the pulse oximeter sensor from your body when your therapy session is finished. You may leave the sensor connected to the USB connector cable between uses.

Follow the user manual supplied with the pulse oximeter sensor and USB connector cable to care for and/or dispose of these devices.

10.4 Troubleshooting

You can tap the pulse oximeter tile to open the Pulse Oximetry screen and view the pulse oximeter status. Status messages you may encounter and troubleshooting steps are shown below. Contact your healthcare provider if the problem persists.

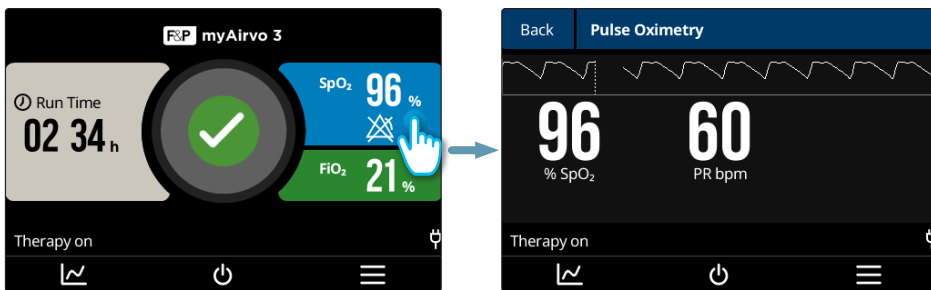

Message	Cause/remedy
Low Signal Quality	<p>Nonin only. The pulse oximeter is indicating low signal quality. The parameters are displayed in grey while in this state.</p> <p>These low signal quality states may be caused by excess motion, low perfusion, a long/blocked light path, or a damaged or incorrectly fitted sensor.</p> <ul style="list-style-type: none"> • Follow the sensor's user instructions to check it is the correct type and that it has been correctly applied to the patient. • Reduce or eliminate motion at the monitoring site. • Consider an adhesive sensor. • Check that the sensor's emitter and detector are properly aligned, particularly when using an adhesive sensor. • Consider a different measurement site. • Check that blood flow to the measurement site is not restricted. • See the <i>Pulse oximetry</i> section for physiological conditions that may affect pulse oximetry measurement accuracy and consider an alternative method if indicated. • Remove excessive fingernail polish or artificial nails. • Replace the sensor. • See the <i>Pulse oximetry</i> section for physiological conditions that may affect pulse oximetry measurement accuracy and consider an alternative method if indicated. • Remove excessive fingernail polish or artificial nails. • Replace the sensor.
Patient Missing	<p>The pulse oximeter cannot detect a patient. Check that the sensor is properly fitted by following the user manual supplied with the sensor. SpO₂ will display "--".</p>
Sensor Disconnected	<p>A pulse oximetry sensor cable was not detected or is inoperable. Check that the sensor cable is properly connected to the USB connector cable or replace the sensor cable if necessary. SpO₂ will display "--".</p>
Communication Failure	<p>Unable to communicate with the pulse oximeter. Check that the USB connector cable, sensor adapter cable and sensor cables are all properly connected. Replace the sensor cable, adapter cable then USB connector cable in turn if the problem persists. SpO₂ will display "--".</p>

No SpO₂ Reading	The pulse oximeter is not sending valid SpO ₂ measurements. Check the sensor, cable and USB interface. Try replacing each component in turn until the problem is resolved
No Pulse Rate Reading	The pulse oximeter is not sending valid Pulse Rate measurements. Check the sensor, cable and USB interface. Try replacing each component in turn until the problem is resolved.

If the myAirvo 3 loses mains power, and an internal battery is fitted, the system will automatically switch over to use the internal battery and pulse oximetry functionality will be maintained including patient settings

If the myAirvo 3 loses mains power and the battery has not been fitted or is depleted, pulse oximetry functionality will be lost. It will be restored once power is restored to myAirvo 3 maintaining patient settings.

10.5 Description of measurements

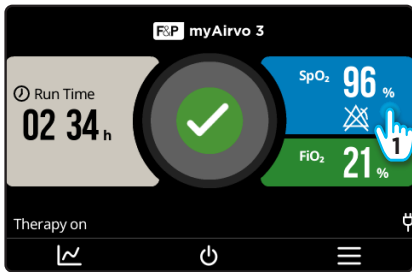

You can tap the pulse oximeter tile to open the Pulse Oximetry screen and view the pulse oximeter status.

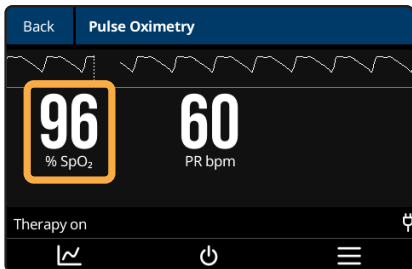

SpO₂

The myAirvo 3 is calibrated to display functional oxygen saturation (SpO₂) as a percentage of oxygenated hemoglobin.

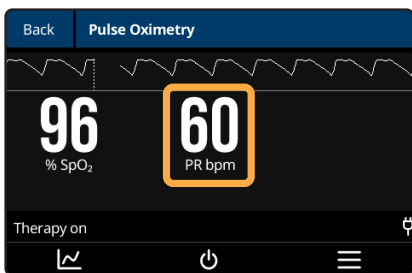

Pulse rate (PR)

Measurements are based on optical detection of pulsatile peripheral blood flow by the pulse oximeter sensor. Pulse rate is displayed in beats per minute (bpm). Pulse rate is included in the data sent to your healthcare provider but is not displayed on the myAirvo home screen.

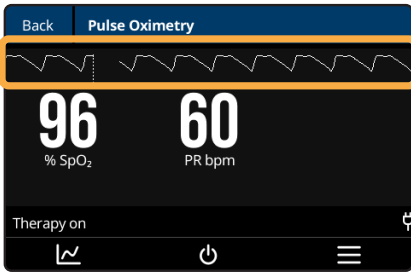

Plethysmograph

A plethysmograph (or photo-plethysmograph) provides a non-normalized indication of the change in blood volume measured by the pulse oximeter sensor. The shape of the plethysmograph may change between patients, between measurement sites and for different sensor models. The plethysmograph provides an indication of signal inadequacy. A low amplitude or variable plethysmograph may indicate poor/inadequate signal. The plethysmograph is displayed on the Pulse Oximetry screen.

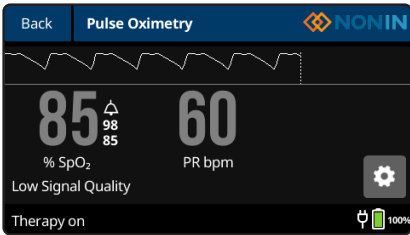

Signal quality indicators (Nonin)

Nonin pulse oximetry equipment indicate signal quality based on the perfusion of the patient.

There are three states: green, yellow, and red corresponding to high, low/marginal, and low/poor signal quality respectively.

The myAirvo 3 indicates low signal quality by greying out the SpO₂ and pulse rate numbers.

11. Advanced settings

Your healthcare provider will set up your myAirvo 3 with the best settings for your therapy. They may suggest changing therapy settings as your condition changes. This chapter will help you adjust these advanced settings when directed by your healthcare provider.

Warning

Always discuss any changes to your therapy with your healthcare provider.

Note

The myAirvo 3 will remember the changes you make to advanced settings. You won't need to change the settings every time you use the device.

11.1 Using the touchscreen

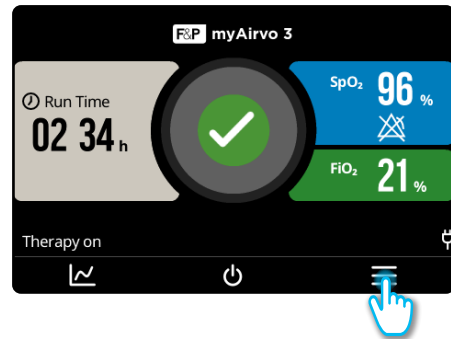

View and adjust therapy settings by:

- tapping  to open the myAirvo menu, where you can view current settings,

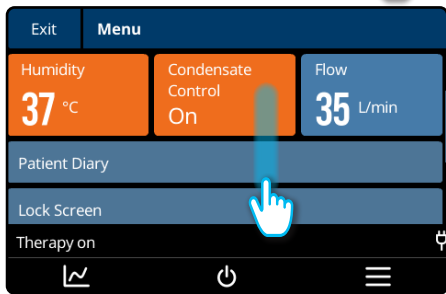

- swiping up/down to scroll through the settings and information available, and

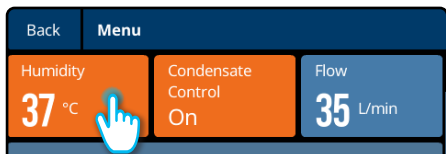

- tapping tiles and buttons on the screen to make selections and change values.

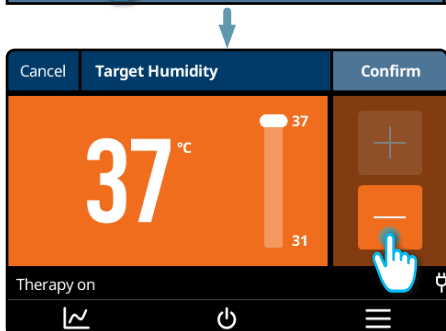

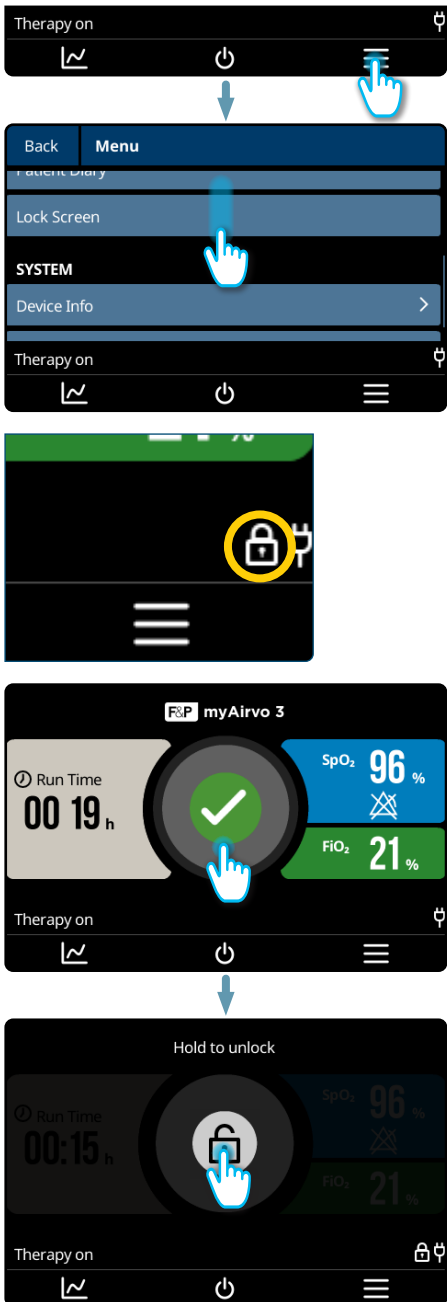

11.2 Touch lock

The myAirvo 3 includes a touch lock which can prevent accidental changes to your therapy (e.g. by children or pets). When the display is locked, the screen will ignore all touches preventing any changes.



To enable the touch lock:

1. Tap  to open the menu.
2. Touch the screen and drag up until **Lock Screen** scrolls into view.
3. Tap **Lock Screen** to lock the screen.
 is shown in the Message bar when the screen is locked.

To disable the touch lock:

1. Tap the screen to see the unlock button.
2. Hold down the unlock button for three seconds.

Note

The touch lock may be disabled by your healthcare provider.

11.3 Therapy settings

Your healthcare provider may ask you to change one or more settings to adjust your therapy. Do not change any settings before discussion with your healthcare provider.

Setting	Range	Description
Target humidity	31 – 37 °C (87.8 – 98.6 °F)	The target temperature of the breathing gas.
Condensate control	Off, On	Condensate Control reduces the amount of condensate produced in the tube.
Target flow	2 – 60 L/min	The target flow setting controls how much air is supplied through the AirSpiral Tube.

Note

Your healthcare provider may limit the range of therapy settings available.

11.3.1 Adjusting the target humidity



1. Tap to open the myAirvo menu.
2. Tap the **Humidity** tile to open the setting page.

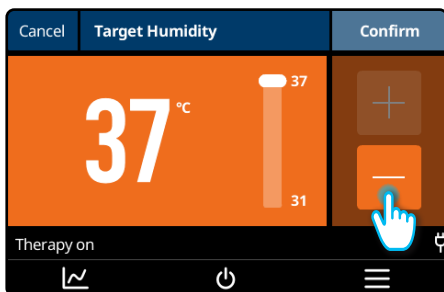

3. Use the **+** / **-** buttons to change the target humidity to the desired value.

Warning

If you have bypassed upper airways (i.e. a tracheostomy), do not set Target Humidity below 37 °C.

Note

Patient's using face masks may find high temperatures uncomfortable. Consider a target humidity of 31 °C (87.8 °F).



4. Tap the **Confirm** button to apply the new target temperature, or the **Cancel** button to leave target temperature unchanged.

11.3.2 Using Condensate Control

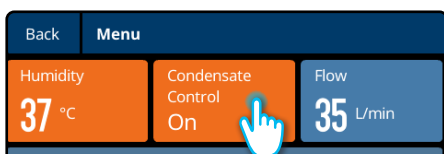

1. Tap to open the myAirvo menu.
2. Tap the **Condensate Control** tile to open the setting page.

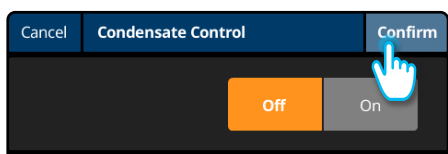
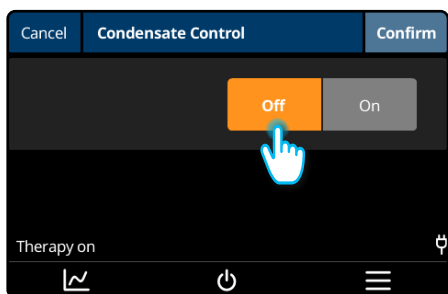

3. To enable or disable **Condensate Control**, select:

- **Off**: normal humidity
- **On**: reduce the delivered humidity while maintaining the same delivered gas temperature.

4. Tap the **Confirm** button to apply the new Condensate Control setting, or the **Cancel** button to leave Condensate Control unchanged.

11.3.3 Night mode

myAirvo 3 contains an automatic "Night mode" which is triggered by low ambient light. During Night mode, all non-alarm sounds (e.g. start-up/ shutdown sounds, user interaction clicks, drying complete, etc.) are silenced and the screen is dimmed.

11.3.4 Adjusting the flow rate

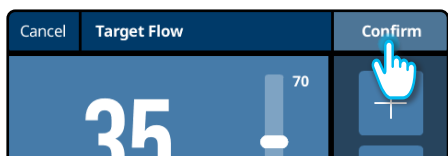
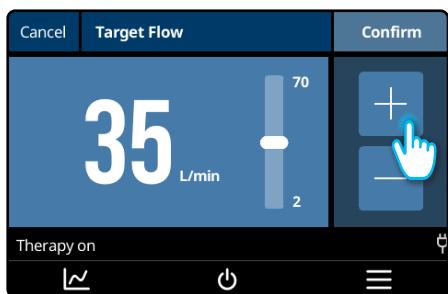

1. Tap **≡** to open the myAirvo menu.

2. Tap the **Flow** tile to open the settings page.

3. Use the **+** / **-** buttons to increase/decrease the target flow until the required value is displayed.

4. Tap the **Confirm** button to apply the new target flow, or the **Cancel** button to leave target flow unchanged.

Warning

Changing the flow rate can affect the concentration of oxygen delivered. Do not change prescribed settings without consulting your physician.

12. Parts and accessories

Contact your healthcare provider to order consumables and accessories.

Warning

Use only genuine Fisher & Paykel Healthcare parts with the myAirvo 3 to avoid possible injury and damage to the device.

12.1 Patient consumables

The patient interfaces and accessories shown in the table below have been tested for use with the myAirvo 3. Take care to follow the user manual supplied with all patient interfaces and accessories.

All patient interfaces are Type BF applied parts.

Description	Part Number	Size	Pack Size
Optiflow+ Nasal Cannula	OPT942E	Small	1
	OPT944E	Medium	1
	OPT946E	Large	1
Optiflow+ Nasal Cannula 2-pack	MYOPT9SMALL	Small	2
	MYOPT9MEDIUM	Medium	2
	MYOPT9LARGE	Large	2
Optiflow+ Duet Asymmetrical Nasal Cannula 2-pack	MYDUETSMALL	Small	2
	MYDUETMEDIUM	Medium	2
	MYDUETLARGE	Large	2
Optiflow Jr 2 Nasal Cannula¹	OJR416HM (WJR112)	L	5
	OJR418HM (WJR112)	XL	5
Tracheostomy Interface	OPT970E	15 mm tracheostomy direct connection	1
Tracheostomy Interface 2-pack	MYOPT9TRACHE	15 mm tracheostomy direct connection	2
Mask Interface Adapter² (vented masks only)	OPT980E	22 mm mask interface adapter	1
Mask Interface Adapter² (vented masks only) 2-pack	MYOPT9MASK	22 mm mask interface adapter	2
Tube and chamber kits			
AirSpiral Tube and Auto-fill Chamber	MYAIRVOKIT1	n/a	1
Water Bag³	900PT401	n/a	1
Reusable Chamber³	MYAIRVOCHAMBER1	n/a	1
Mobile Pole Stand	900PT421	n/a	1
Compact Stand	900PT400	n/a	1
Tube kits³			
AirSpiral tube kit	MYAIRSPIRAL	n/a	1
AirSpiral tube kit	900PT560E	n/a	1
AirSpiral tube kit	900PT560	n/a	10

Notes:

- Part numbers for replacement wiggle pads are shown in parenthesis.
- The mask interface adapter is designed for vented masks only. Do not use sealed masks with the myAirvo 3.
- Maximum water chamber liquid volume:
 Reusable Chamber 560 mL
 Auto-fill Chamber 100 mL
 Water Bag 1000 mL

12.2 Replacement parts and accessories

Description	Part Number
Air filter	900PT933
Battery‡	900PT957L
Disinfection kit†	900PT620
Spare outlet elbow	900PT930
InfoUSB	900PT470
myAirvo 3 is compatible with F&P InfoSmart	F&P InfoSmart
Fisher & Paykel Healthcare Device Manager	900PT475

‡ See myAirvo 3 Technical Guide for instructions to change the battery.

† A Disinfection kit is required when using the built-in validated thermal disinfection to clean and disinfect the outlet elbow between patients.

12.3 Pulse oximeter sensors and accessories

Pulse oximeter sensors, cables and adapters shown below have been validated to be compatible with myAirvo 3. Carefully read the user manual, including all warnings and cautions, supplied with each device before use.

Nonin:

Part numbers of compatible Nonin pulse oximetry USB connector cables

Description	Nonin part number (cable length)
3012LP Xpod USB connector	6703-001 (1m, 3ft)

Part numbers of compatible Nonin pulse oximeter sensor cables

Sensor description	Nonin part number (cable length) (other information)
8000SS reusable soft sensors, small	6837-000 (1m, 3ft), 6837-300 (3m, 10ft)
8000SM reusable soft sensors, medium	6836-000 (1m, 3ft), 6836-300 (3m, 10ft)
8000SL reusable soft sensors, large	6835-000 (1m, 3ft), 6835-300 (3m, 10ft)
8000AA adult reusable finger clip sensors	3278-001 (1m, 3ft), 3278-006 (2m, 6ft), 3278-003 (3m, 10ft)
8000AP pediatric reusable finger clip sensors	2360-000 (1m, 3ft), 2360-003 (3m, 10ft)
8000Q2 ear clip sensor	6455-000 (1m, 3ft)
8000R reflectance sensor	0487-000 (1m, 3ft)
8000J adult semi-reusable FlexSensor	0741-000 (1m, 3ft), 2353-002 (3m, 10ft) (includes x25 8000JFW FlexiWraps®)
8008J infant semi-reusable FlexSensor	0740-000 (1m, 3ft) (includes x25 8008JFW FlexiWraps)
6000CA adult cloth disposable sensors	7426-001 (1m, 3ft) (24 pack)
6000CP pediatric cloth disposable sensors	7426-002 (1m, 3ft) (24 pack)
6000CI infant cloth disposable sensors	7426-003 (1m, 3ft) (24 pack)
7000A adult Flexi-Form® III disposable sensors	7427-001 (1m, 3ft) (24 pack)

7000P pediatric Flexi-Form III disposable sensors	7427-002 (1m, 3ft) (24 pack)
7000I infant Flexi-Form III disposable sensors	7427-003 (1m, 3ft) (24 pack)
8000JFW adult FlexiWraps	4097-000, (25 pack), for use with 8000J
8008JFW infant FlexiWraps	4774-000, (25 pack), for use with 8008J
8000H reflectance sensor holder pack	0616-000, (10 caps & 20 adhesive stickers) for use with 8000R
Sensor Clip for LP Xpod External Pulse Oximeter	7504-001

Nonin™, Xpod®, PureLight®, PureSAT®, FlexiWraps®, Flexi-Form® are trademarks of Nonin Medical Inc.

13. Specifications

General

Dimensions	205 mm x 295 mm x 190 mm (8.0" x 11.7" x 7.5")
Weight device only	4.45 kg (9.8 lb.)
Supply voltage/current	100 – 115 VAC, 2.4 A (2.6 A max ¹) 220 – 240 VAC, 1.1 A (1.3 A max ¹)
Supply frequency	50 – 60 Hz
USB port sourcing (1 and 2)	USB 2.0 Type A 5 V, 0.25 A (maximum each port)
Sound level	< 50 dBA @ 1 m
Auditory alarm	
Sound pressure level	> 40 dBA @ 1m
Mute duration	120 s duration
Ingress protection	IP22 ²
Expected service life	5 years ³

Operating conditions

Ambient temperature	18 – 28 °C (64 – 82 °F)
Humidity	10 – 95% relative humidity (non-condensing)
Ambient pressure	700 - 1060 hPa
Altitude	0 - 3000 m (9840 ft)
Mode of operation	Continuous operation
Maximum delivered dew-point temperature of respiratory gas	43 °C (109 °F)
Maximum surface temperature of applied parts⁴	44 °C (111 °F)
Maximum water chamber liquid volume	
Reusable Chamber	560 mL
Auto-fill Chamber	100mL
Water Bag	1000mL

Storage and transport conditions

Ambient temperature^{5,6}	-10 – 50 °C (14 – 122 °F)
Humidity (non-condensing)	10 – 95% relative humidity

Operating, transporting or storing the device outside the permissible environment conditions specified may result in degraded performance.

Optional battery (900PT957L)

Chemistry	Lithium Ion (Li-Ion)
Voltage	14.4 VDC
Capacity	≤ 99.4 Wh
Power output	80 W
Battery life	300 charge/discharge cycles or 2 years from first use (whichever comes first)

Recharge time	6 hours (max.)
Shelf life	3 years
Operating time⁷ to 20%	
Typical	50 minutes

Communications

Cellular modem⁸
Depending on device model and market, any of the following frequency bands may be applicable.

UMTS 3G	B1, B5, B8 Max. power 24 dBm +1 / -3
LTE Cat-M	B1, B2, B3, B4, B5, B8, B12, B13, B14, B17, B18, B19, B20, B25, B26, B27, B28, B66 Max. power 23 dBm ± 1.5
LTE Cat-1	B3, B5, B8, B28 Max. power 23 dBm ± 2

Supplementary oxygen

Maximum flow rate	15 L/min oxygen (STPD ⁹)
Oxygen sensor	
Startup time	< 30 s
Response time	< 60 s
Range	21 - 100% O ₂

Optiflow high flow therapy^{10, 14}

Target humidity range	31 – 37 °C (87.8 – 98.6 °F)
Target flow range¹¹	2 - 60 L/min
Maximum limited pressure¹²	60 cmH ₂ O
Maximum operating pressure	< 45 cmH ₂ O
Humidity⁴	
Wall-power	> 33 mg/L @ 37 °C target humidity, 10-60L/min target flow > 16mg/L for all other settings
Static temperature stability	± 2 °C
Warm up time¹⁵ (Auto-fill Chamber)	
23 ± 2 °C to 37 °C (73 ± 3.6°F to 88 °F)	< 20 minutes @ 60 L/min flow rate
Warm up time¹⁵ (Reusable Chamber)	
23 ± 2 °C to 37 °C (73 ± 3.6°F to 98.6 °F)	< 40 minutes @ 60 L/min flow rate

Notes:

1. Inrush current may reach 50 A.
2. The device is protected against harmful effects of dripping water when tilted by up to 15° and/or incursion of fingers or similar sized objects.
3. Assumes typical usage pattern. Actual service life may vary.
4. In accordance with ISO 80601-2-74. Tested to an accuracy of $\pm 1\text{ }^{\circ}\text{C}$ or $\pm 1\text{ mg/L}$ as appropriate.
5. Storage at temperatures above 40 °C (104 °F) for prolonged periods will accelerate battery degradation.
6. The device may require up to 24 hours to equilibrate to operating temperature before it is ready for use.
7. For humidity performance under battery use, see Appendix 1.
8. Country and carrier dependent.
9. Flow rate is expressed in STPD (standard temperature and pressure, dry) as per ISO 80601-2-74.
10. Values are expressed in BTPS (body temperature, pressure, saturated) unless otherwise stated.
11. Maximum achievable flow rate depends on the patient interface selected.
12. In accordance with ISO 80601-2-90.
13. Applies when the device is connected to a wall power supply for warm up.
14. To meet safety and performance standards, the system has been tested using the worst case breathing system setup. This setup includes 900PT561 with OPT970 interface for bypassed airway, and OPT966 interface for all other test cases.

Range and accuracy of measured parameters

Measurement	Symbol	Range	Accuracy
Humidity	Temp	31 – 37 °C	Not specified
Flow rate	Flow	2 – 60 L/min	$\pm (1 + 5\% \text{ of reading})\text{ L/min}^*$
Oxygen concentration†	FiO ₂	21 – 100%	Lower of: $\pm 4\%$, or $\pm (2.5\% + 2.5\% \text{ of reading})$ - excluding rounding to 21% and 100%, as appropriate - provided "Oxygen concentration" setting is correct
Peripheral blood oxygen saturation	SpO ₂	1 – 100%	See pulse oximetry specifications below.
Pulse rate	PR / 	Nonin 18-321 beats/min	See pulse oximetry specifications below.

* Test equipment and methods are selected and controlled to ensure the uncertainty coverage is no more than 30% of the disclosed tolerance.

† Oxygen measurements are automatically compensated for changes in barometric pressure.

‡ A RMS accuracy is a statistical calculation of the difference between device measurements and reference measurements. Approximately two-thirds of the device measurements fell within +/- ARMS of the reference measurements in a controlled study.

Pulse oximetry

Specifications are tabulated for the myAirvo 3 and all compatible sensors unless otherwise stated.

Nonin:

Data Update Period	<30 sec
Measurement Wavelengths and Output Power*	Red: 660 nm @ 0.8 mW max. avg. Infrared: 910 nm @ 1.2 mW max avg. (using Nonin Purelight® Sensor)
SpO₂ Accuracy (A_{rms}**) No Motion	70 to 100% Adults/Pediatrics***
Reusable	
8000AX Series:	± 2 digits
800XJ Series:	± 3 digits
8000SX Series:	± 2 digits
8000R:	± 3 digits
8000Q2:	± 3 digits
Disposable	
6000CX Series:	± 2 digits
7000X Series:	± 2 digits
Motion	
Reusable	
8000AX Series:	± 2 digits
800XJ Series:	± 3 digits
8000SX Series:	± 3 digits
Low Perfusion****	± 2 digits
Pulse Rate Accuracy	Adults/Pediatrics***
No Motion (18 - 300 BPM)	
Reusable	
8000AX Series:	± 3 digits
800XJ Series:	± 3 digits
8000SX Series:	± 3 digits
8000R:	± 3 digits
8000Q2:	± 3 digits
Disposable	
6000CX Series:	± 3 digits
7000X Series:	± 3 digits
Motion (40 - 240 BPM)	
Reusable	
8000AX Series:	± 5 digits
800XJ Series:	± 5 digits
8000SX Series:	± 5 digits
Low perfusion (40 - 240 BPM)****	± 3 digits

* This information is especially useful for clinicians performing photodynamic therapy.

** ± 1 A_{rms} represents approximately 68% of measurements.

*** Includes Infant patients

Notes:

- SpO₂ accuracy testing is conducted during induced hypoxia studies on healthy, non-smoking, light-to-dark-skinned subjects during motion and no-motion conditions in an independent research laboratory. The measured arterial hemoglobin saturation value (SpO₂) of the sensors is compared to arterial hemoglobin oxygen (SaO₂) value, determined from blood samples with a laboratory co-oximeter. The accuracy of the sensors in comparison to the co-oximeter samples measured over the SpO₂ range of 70 - 100%. Accuracy data is calculated using the root-mean-squared (Arms value) for all subjects, per ISO 80601-2-61 formerly ISO 9919, Standard Specification for Pulse Oximeters for Accuracy.
- Pulse rate motion testing measures pulse rate accuracy with motion artifact simulation introduced by an Oxitest Plus7 pulse oximeter tester. This test determines whether the oximeter meets the criteria of ISO 80601-2-61, formerly ISO 9919, for pulse rate during simulated movement, tremor, and spike motions.
- Low perfusion testing uses an SpO₂ Simulator to provide a simulated pulse rate, with adjustable amplitude settings at various SpO₂ levels. The module must maintain accuracy in accordance with ISO 80601-2-61, formerly ISO 9919, pulse rate and SpO₂ at the lowest obtainable pulse amplitude (0.3% modulation).
- The Nonin Xpod has been validated for pulse rate accuracy from 18-300 bpm with no motion and from 40-240 bpm with motion. Testing was carried out using a Datrend Oxitest Plus 7 simulator.

13.1 Oxygen fraction

The fraction of oxygen delivered to the patient depends on:

1. the flow rate setting on the myAirvo 3, and
2. the flow rate of the oxygen supply connected to the low-pressure inlet port on the top of the myAirvo 3.

The concentration of oxygen delivered varies significantly at target flow rates below 10 L/min with small changes in the flow rate from supplementary oxygen supply.

Warning

- Always check that suitable SpO₂ levels are achieved with the prescribed therapy.
- Use continuous SpO₂ monitoring on patients who would desaturate significantly in the event of disruption to their oxygen supply.
- The fraction of oxygen inspired by the patient will be lower than the value displayed if the patient's peak inspiratory demand exceeds the flow delivered. When the patient's inspiratory demand exceeds the flow delivered by the myAirvo 3 the patient will draw in room air during inhalation. Inhalation of room air will dilute FiO₂, (particularly when the oxygen concentration selected on the myAirvo 3 is high).

13.2 Standards and approvals

Designed to conform to the following standards:

IEC 60601-1:2005 + A1:2012 + A2:2020 (ed 3.2)

IEC 60601-1-2:2014 + A1:2020 (ed 4.1)

IEC 60601-1-11:2015 + A1:2020

ISO 80601-2-61:2017

ISO 80601-2-74:2017 (ed 2.0)

ISO 80601-2-90:2021

Do not place any part of the device or accessories within 30 cm (12") of any portable mobile radio frequency communication equipment. The myAirvo 3 complies with the electromagnetic compatibility requirements of IEC 60601-1-2. In certain circumstances, the unit may affect or be affected by nearby equipment due to the effects of electromagnetic interference. Excessive electromagnetic interference may affect the therapy delivered by the device. If this should happen, try moving the myAirvo 3 or the location of the unit causing interference, or alternatively consult your healthcare provider.

FCC compliance

This device has been tested and found to comply with the limits for a Class B digital device, pursuant to part 15 of the FCC Rules. These limits are designed to provide reasonable protection against harmful interference in a residential installation. This device generates, uses, and can radiate radio frequency energy and, if not installed and used in accordance with the instructions, may cause harmful interference to radio communications. However, there is no guarantee that interference will not occur in a particular installation. If this device does cause harmful interference to radio or television reception, which can be determined by turning the device off and on, the user is encouraged to try to correct the interference by one or more of the following measures:

- Reposition or relocate the receiving antenna.
- Increase the separation between the device and receiver.
- Connect the device into an outlet on a circuit different from that to which the receiver is connected.
- Consult your healthcare provider or your Fisher & Paykel Healthcare representative for help.

If the Medical Equipment system is modified from the specification of the manufacturer, evaluation to the requirements of 60601-1 standard is required.

Accessory equipment connected to the any port of the myAirvo 3 must be certified to IEC 60601-1 or IEC 60950-1. All configurations shall comply with the system standard IEC 60601-1-1. Anyone who connects additional equipment to the signal input part or signal output part configures a medical system and is therefore responsible for ensuring that the system complies with the requirements of the system standard IEC 60601-1. If in doubt, consult your technical services department or your local Fisher & Paykel Healthcare representative.

Certain elements of the software included with product are supplied under the licence terms of third parties, including elements of the software that are subject to certain open source software licences. Where required by the terms of these licences, Fisher & Paykel Healthcare Limited provides notices regarding such software elements on its website. Please visit <https://www.fphcare.com/airvo3/third-party-licenses> to view these notices. Note that the notices that apply may be updated as the software included in the product is updated.

13.3 Device disposal instructions

This device contains electronic components and a lithium-ion battery. Regulations in your country may require them to be collected for waste recovery and recycling to reduce the environmental impact. Please dispose of this device in accordance with local regulations.









13.4 Disposal of accessories, spare parts and packaging

Dispose of accessories, spare parts and packaging according to local guidelines. Place the breathing tube, and water chamber in a waste bag at the end of use and discard with normal waste. Hospitals should discard according to their standard method for disposing of contaminated product.

14. Glossary





























14.1 Status icons

Status icons are displayed on the [status bar](#).

Icon	Description
	The myAirvo 3 is being powered from a wall power supply.
	Touchscreen is locked to prevent accidental changes
	myAirvo 3 InfoUSB device is connected
 100%	Status of the internal battery (only when the optional battery is installed):
 50%	50% of the battery charge is remaining
 50%	Battery is charging (currently at 50% of its capacity)
 50%	Battery is not charging properly [†]
	Battery is missing or faulty [†]
	Battery is due for replacement [†]

[†] Check the battery is properly installed. Replace the battery if the problem persists.

14.2 Symbols

 <p>For safety reasons, refer to the instructions for use</p>	 <p>Warning, hot surface</p>	 <p>Consult instructions for use for detailed information</p>	 <p>Power on/off button</p>
 <p>System menu button</p>	 <p>Alarm limits</p>	 <p>Data and Graphs information button</p>	 <p>Pulse rate</p>
 <p>USB port and Compatible USB device detected</p>	 <p>Alarm symbol</p>	 <p>No SpO₂ or pulse rate alarms</p>	 <p>Class II equipment (double insulated)</p>
 <p>Temperature range</p>	 <p>Humidity range</p>	 <p>Type BF applied part (body floating)</p>	<p>Rx only Prescription only</p>
<p>IP22 Protected against ingress of small objects and water drops</p>	 <p>Operating conditions</p>	 <p>Storage and transport conditions</p>	 <p>YYYY-MM-DD Date of manufacturer</p>
 <p>Manufacturer</p>	 <p>Magnetic Resonance (MR) Unsafe</p>	 <p>Non-ionizing electromagnetic radiation</p>	 <p>YYYY-MM-DD Date of manufacturer</p>
 <p>Serial number</p>	 <p>Catalogue number</p>	 <p>Batch code</p>	 <p>UL Classified Mark Canada, USA</p>
 <p>Regulatory compliance mark (RCM)</p>	 <p>Importer</p>	 <p>Distributor</p>	

14.3 Terms

bpm: unit for pulse rate (beats per minute).

Breathing gas: see Respiratory gas.

Breathing tube: a heated tube that delivers air flows from the myAirvo 3 to a patient interface.

Cannula: a device used to deliver supplementary oxygen or increased air flow through the nasal cavity.

COHb: carboxyhemoglobin.

Condensation: water droplets that form on cold surfaces.

Dew-point temperature: a measure of humidity (water vapor) in a gas, expressed as the temperature of a surface where liquid water would begin to form.

Distilled water: water that has been boiled into vapor and condensed back into liquid in a separate container to remove impurities.

ECG: electrocardiogram.

EEG: electroencephalogram.

Effective hemoglobin: the hemoglobin in the blood which is capable of transporting oxygen.

EKG: electrocardiogram.

EMG: electromyography.

Expiration: breathing out.

FiO₂: the concentration of oxygen in the breathing gases delivered to the patient.

Flow rate: the volume of air delivered by the myAirvo 3. Measured in liters per minute.

Functional oxygen saturation: the fraction of effective hemoglobin which is oxygenated.

Heater plate: the hot metal plate at the front of the myAirvo 3 which heats the water chamber.

Humidity: a measure of the amount of water vapor in a gas. Inspiration: breathing in.

L/min: liters per minute. A measure of flow rate.

Mask interface adapter: a patient interface that supplies breathing gas to a connected mask.

MetHb: methemoglobin.

Nasal interface: a patient interface that supplies breathing gas through your nose.

Oxygen concentrator: a device that increases the concentration of oxygen in a supply of air by removing nitrogen gas.

Oxygen source: a supply of oxygen such as an oxygen bottle or oxygen concentrator.

Drinking quality water: water suitable for drinking.

PR: pulse rate.

Relative humidity: a measure of the water vapor content of a gas relative to the water vapor content above still water in a closed container.

Respiratory gas: air supplied by the myAirvo 3 to the patient. The breathing gas may have a higher concentration of oxygen than room air.

SaO₂: arterial blood oxygen saturation.

SpO₂: peripheral capillary oxygen saturation.

Tracheostomy interface: a patient interface that supplies breathing gas through a tracheostomy port.

USB: universal serial bus.

Water chamber: a container of water that is heated to humidify the breathing gases.

Water supply tube: the thin tube used to connect the Auto-fill Chamber to the Water Bag.

Appendix 1. Humidification behavior during battery operation

The myAirvo 3 reduces the energy used to humidify breathing gases when not powered from a wall power supply, to conserve battery power. In all cases, the myAirvo 3 continues supplying supplementary oxygen and breathing gases until the battery is depleted.

For Optiflow high flow, active humidification of the breathing gases is reduced during battery operation. If the Critically Low Battery alarm is raised, active humidification is stopped to conserve battery power.

Connect the myAirvo 3 to a wall power supply before the battery is empty to automatically resume normal therapy. If the myAirvo 3 battery is depleted, the device stops supplying supplementary oxygen and breathing gases, powers down and produces the Power Out alarm. To resume therapy after the device has powered down, connect the myAirvo 3 to a wall power supply.

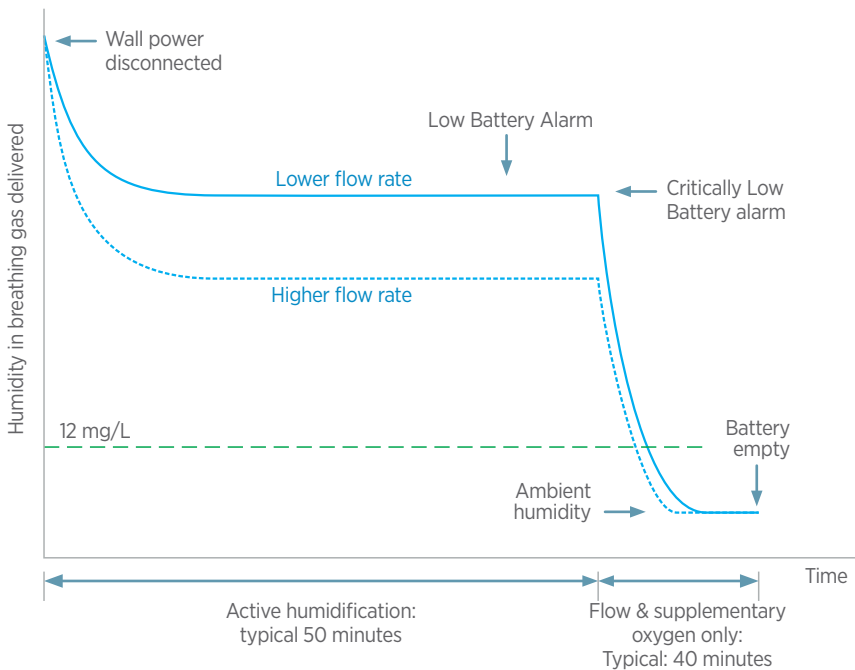

The myAirvo 3 delivers reduced humidity in the breathing gas during Optiflow high flow therapy until the battery is nearly depleted, where humidity is turned off to maintain the delivery of flow and oxygen.



Fisher & Paykel Healthcare Ltd, 15 Maurice Paykel Place, East Tamaki, Auckland 2013, PO Box 14 348 Panmure, Auckland 1741, New Zealand Tel: +64 9 574 0100 Email: info@fphcare.co.nz Web: www.fphcare.com



Australia (AU) (Sponsor) Fisher & Paykel Healthcare Pty Ltd, 19-31 King Street, Nunawading, Melbourne, Victoria 3131.



Tel: +61 3 9871 4900 **Brazil (BR)** Fisher & Paykel do Brasil, Rua Sampaio Viana, 277 cj 21, Paraíso, 04004-000, São Paulo - SP, Brazil Tel: +55 11 2548 7002

China (CN) 代理人/售后服务机构:费雪派克医疗保健 (广州) 有限公司, 广州高新技术产业开发区科学城科丰路31号G12栋301号 电话: +86 20 32053486 **Colombia (CO)** Tel: +57 3142852934

France (FR)  Fisher & Paykel Healthcare SAS, 10 Av. du Québec, Bât F5, BP 512, Villebon-sur-Yvette, 91946 Courtaboef Cedex, France Tel: +33 1 6446 5201 Email: c.s@fphcare.fr **Germany (DE)** Fisher & Paykel Healthcare GmbH, Wiesenstrasse 49, 73614 Schorndorf, Germany Tel: +49 7181 98599 0

Hong Kong (HK) Tel: +852 2116 0032 **India (IN)**

Tel: +91 80 2309 6400 **Indonesia (ID)** Tel: +62 21 509 13476 **Japan (JP)** Tel: +81 3 5117 7110 Fax: +81 3 5117 7115 **Korea (KR)**

Tel: +82 2 6205 6900 **Mexico (MX)** Tel: +52 55 9130 1626 **Poland (PL)** Fisher & Paykel Healthcare Poland Sp. z o.o., Pl. Andersa 7, 61-894 Poznań, Poland Tel: +48 664 846 464

Russia (RU) Tel: +7 495 782 21 50 **Sweden (SE)** Fisher & Paykel Healthcare AB, Svetsarvägen 15, 2tr, 17141 Solna, Sweden Tel: +46 8 564 76 680

Switzerland (CH)  Fisher & Paykel Healthcare GmbH, Säntisstrasse 2, 9501 Wil / SG, Switzerland Tel: 0800 83 47 63

Taiwan (TW) Tel: +886 2 8751 1739

Turkey (TR) İthalatçı Firma: Fisher Paykel Sağlık Ürünleri Ticaret Limited Şirketi, İletişim Bilgileri: Ostim Mahallesi 1249. Cadde No:6, Yenimahalle, Ankara, Türkiye 06374, Tel: +90 312 354 34 12

UK (GB)  Fisher & Paykel Healthcare Ltd, Unit 16, Cordwallis Park, Clivemont Road, Maidenhead, Berkshire SL6 7BU, UK Tel: 0800 132 189

USA (US)/Canada (CA) Tel: 1800 446 3908 or +1 949 453 4000

Austria (AT) Tel: 0800 29 31 23 **Benelux (BE NL LU)** Tel: +31 40 216 3555 **Denmark (DK)** Tel: +45 70 26 37 70 **Finland (FI)**



Tel: +358 9 251 66 123 **Ireland (IE)** Tel: 1800 409 011 **Italy (IT)** Tel: +39 06 45 25 70 85 **Norway (NO)** Tel: +47 21 60 13 53

Spain (ES) Tel: +34 910 38 81 18

For more information please contact your local Fisher & Paykel Healthcare representative.