

# 900MR303 MOUNTING KIT – GENERAL PURPOSE RAIL

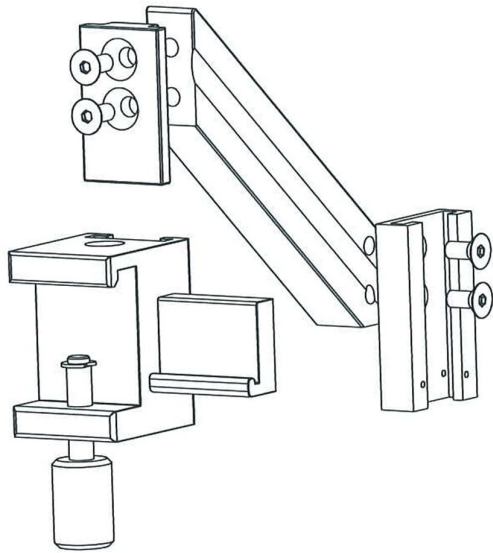

AEQUITRON

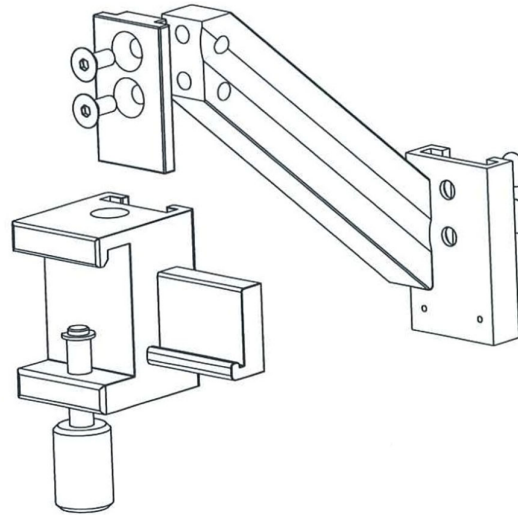

DRÄGER

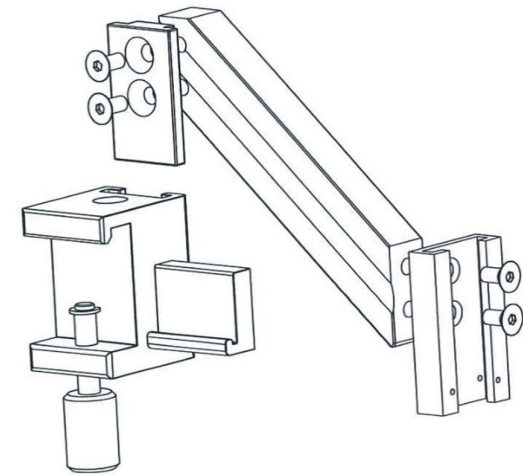

SERVO-i®



**Fisher & Paykel**  
HEALTHCARE

**Manufacturer** Fisher & Paykel Healthcare Ltd, 15 Maurice Paykel Place, East Tamaki, Auckland 2013, PO Box 14 348 Panmure, Auckland 1741, New Zealand Tel: +64 9 574 0100 Fax: +64 9 574 0158 Email: info@fphcare.co.nz Web: www.fphcare.com Importer/ Distributor  
**Australia** (Sponsor) Fisher & Paykel Healthcare Pty Ltd, 19-31 King Street, Nunawading, Melbourne, Victoria 3131. Tel: +61 3 9871 4900 Fax: +61 3 9871 4998 **Austria** Tel: 0800 29 31 23 Fax: 0800 29 31 22 **Benelux** Tel: +31 40 216 3555 Fax: +31 40 216 3554  
**Brazil** Fisher & Paykel do Brasil, Rua Sampaio Viana, 277 cj 21, Paraíso, 04004-000, São Paulo – SP, Brazil Tel: +55 11 2548 7002 **China** 代理人/售后服务机构: 费雪派克医疗保健(广州)有限公司, 广州高新技术产业开发区科学城科丰路31号 G12栋301号 电话: +86 20 32053486 传真: +86 20 32052132 **Denmark** Tel: +45 70 26 37 70 Fax: +46 83 66 310 **Finland** Tel: +358 9 251 66 123 Fax: +46 83 66 310 **France** Fisher & Paykel Healthcare SAS, 10 Av. du Québec, Bât. F5, BP 512, Villebon-sur-Yvette, 91946 Courtaboeuf Cedex, France Tel: +33 1 6446 5201 Fax: +33 1 6446 5221 Email: c.s@fphcare.fr **Germany** Fisher & Paykel Healthcare GmbH & Co. KG, Deutschland, Österreich, Schweiz, Wiesenstrasse 49, D 73614 Schorndorf, Germany Tel: +49 7181 98599 0 Fax: +49 7181 98599 66 **Hong Kong** Tel: +852 2116 0032 Fax: +852 2116 0085 **India** Tel: +91 80 2309 6400 **Ireland** Tel: 1800 409 011 Fax: +44 1628 626 146 **Italy** Tel: +39 06 7839 2939 Fax: +39 06 7814 7709  
**Japan** Tel: +81 3 5117 7110 Fax: +81 3 5117 7115 **Korea** Tel: +82 2 6205 6900 Fax: +82 2 6309 6901 **Norway** Tel: +47 21 60 13 53 Fax: +47 22 99 60 10 **Russia** Tel. and Fax: +7 495 782 21 50 **Spain** Tel: +34 902 013 346 Fax: +34 902 013 379  
**Sweden** Tel: +46 8 564 76 680 Fax: +46 8 36 63 10 **Switzerland** Tel: 0800 83 47 63 Fax: 0800 83 47 54 **Taiwan** Tel: +886 2 8751 1739 Fax: +886 2 8751 5625 **Turkey** İthalatçı Firma: Fisher Paykel Sağlık Ürünleri Ticaret Limited Şirketi, İletişim Bilgileri: Ostim Mahallesi 1249. Cadde No:6, Yenimahalle, Ankara, Türkiye 06374, Tel: +90 312 354 34 12 Fax: +90 312 354 31 01 **UK** Fisher & Paykel Healthcare Ltd, Unit 16, Cordwallis Park, Clivemont Road, Maidenhead, Berkshire SL6 7BU, UK Tel: 0800 132 189 Fax: +44 1628 626 146 **USA/Canada** Tel: 1800 446 3908 or +1 949 453 4000 Fax: +1 949 453 4001

California residents please be advised of the following, pursuant to Proposition 65:

**Warning:** This product contains chemicals known to the State of California to cause cancer, birth defects and other reproductive harm.

For more information, please visit: [www.fphcare.com/prop65](http://www.fphcare.com/prop65)

REF 185042268 Rev J 2019-07 © 2019 Fisher & Paykel Healthcare Limited